

PNM Prosperity
Solar PV Field. A world first...

Cloudshine

© 2021

“Enabling Solar Now.”

Energy Storage

*Anthony Menicucci PhD,
(Dr. A);
amen@unm.edu;
<https://armatech.us/>
20210409 ©*



*Cloudshine
an ArmaTech LLC Company*

© 2019,
ArmaTech LLC

“The Solar revolution will not be, and has never been, a solar revolution.

It has been, and will be, an Energy Storage Revolution.”

Anthony Menicucci Ph.D. (Dr. A.) 2017



What are the problems with Solar integration?

Clouds & Batteries...

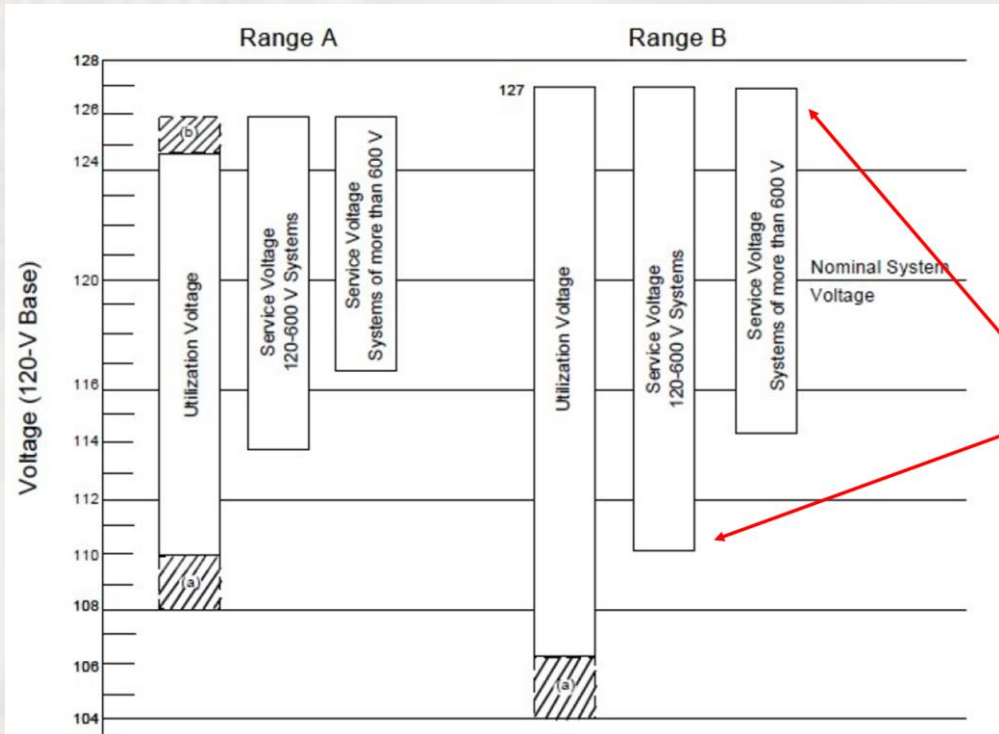

Supplied voltages to customers must remain between 110 and 127 VAC.

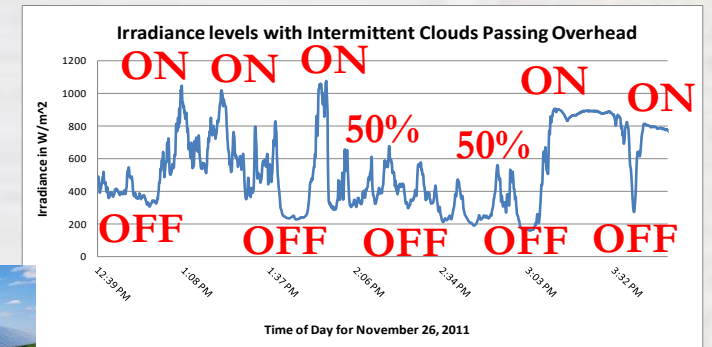

Anthony Menicucci
 PhD. (Dr. A);
amen@unm.edu;
<https://armatech.us/>
 20210409



- *Large Batteries are Expensive*
- *Smoothing Energy Storage is Cost-Effective (20 min. or less)*

*Poor Quality,
Intermittent Power
from PV Field*



*Smoothed
Power Output,
Grid Friendly*

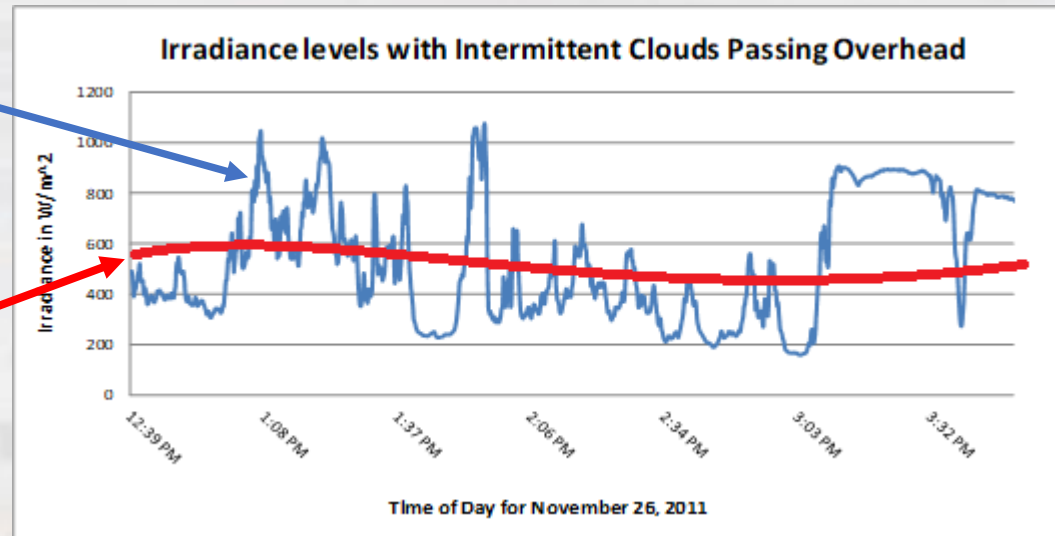

*Anthony Menicucci;
PhD. (Dr. A);
amen@unm.edu;
<https://armatech.us/>
20210409*



Isn't there a better way?



*Smaller, Grid
Tied Storage
(20 min or less)*

+

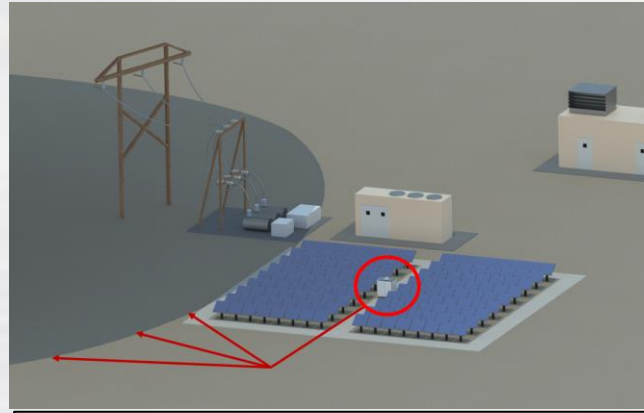

*Short Term Solar
Forecasting
(5 min or less)*

=

*Cost Effective
Smoothing
Solution.*

33% less energy
25% less power
SAME Effect

*“Plug & Play”
Solar Energy Smoothing Solution*

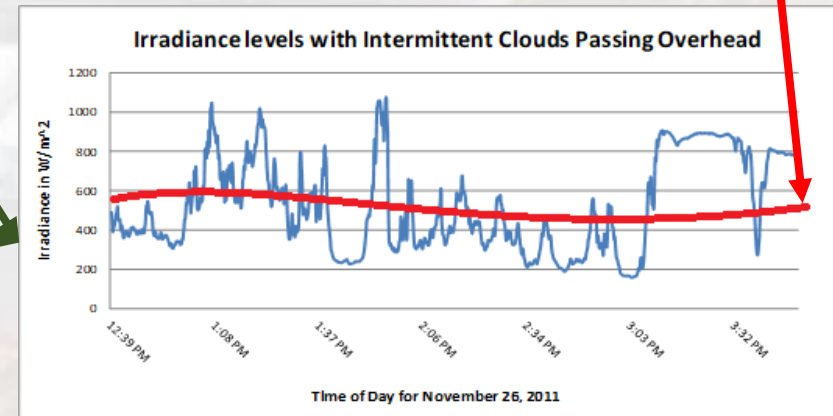

Benefits were validated by our customer feedback:

1. 33% & 27% Power & Energy Reduction (cost effective)
2. Utilities will be able to meet their Renewable Portfolio Standards (RPS) legislation.
3. Meets California mandated energy storage laws.
4. Integrates with current Natural Gas & Battery infrastructure.

Benefits

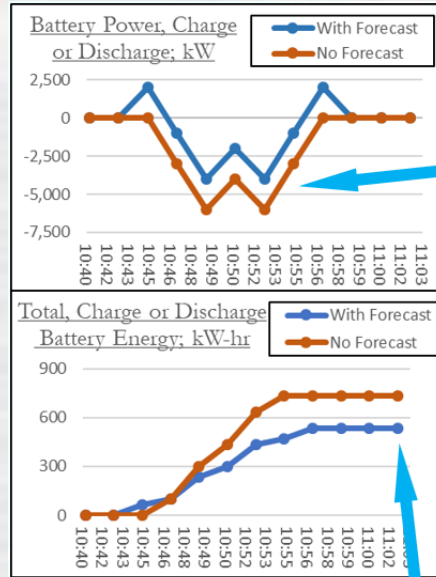

33% Less Flywheel Wear & Tear W. SIMF

27% Smaller Flywheel Capacity W. SIMF

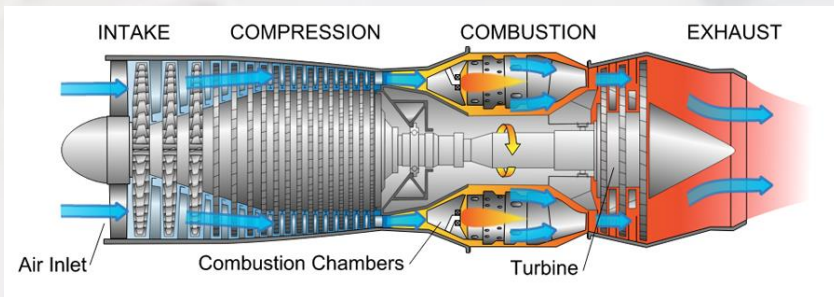

Prototype STTR NSF 16-555;

Proven Fielded Trials, 75+ hrs.

2X Patents issued

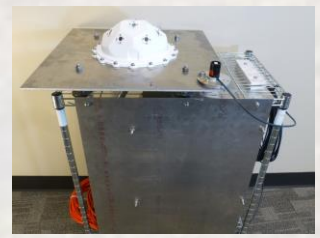

Forecasting Competitors

- Indirect observation with Satellites, LIDAR and Radar. (20-30 min. **too slow**)
- Weather forecasts are used for day-ahead predictions. (**way too slow**)
- No cost effective smoothing solution exists, as *“plug and play”*

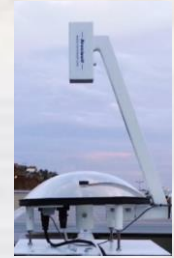

*Older technology competitors
with indirect observation.*

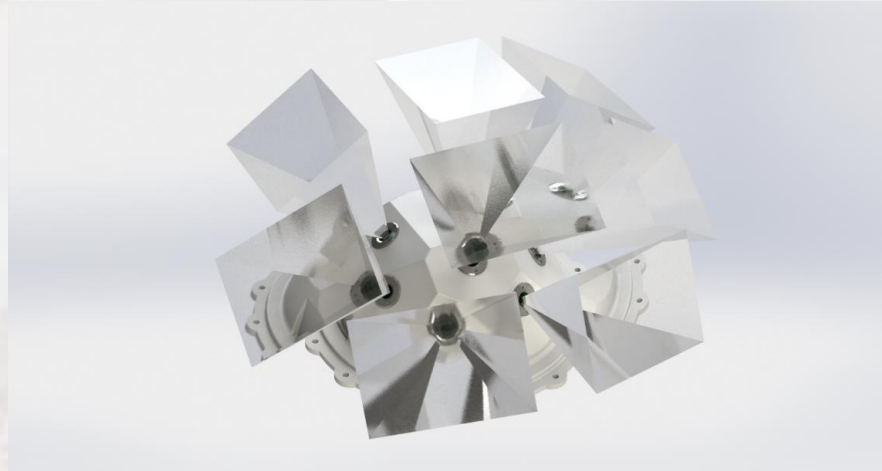

CloudshineTM utilizes state of the art sensors to generate crisp images and an AI that learns solar fields and predicts irradiance accurately, in less than 10 minutes.



As clouds approach, solar power will turn off.

Forecasting

CloudshineTM predicts these occlusion events within 10 minutes at the PV field

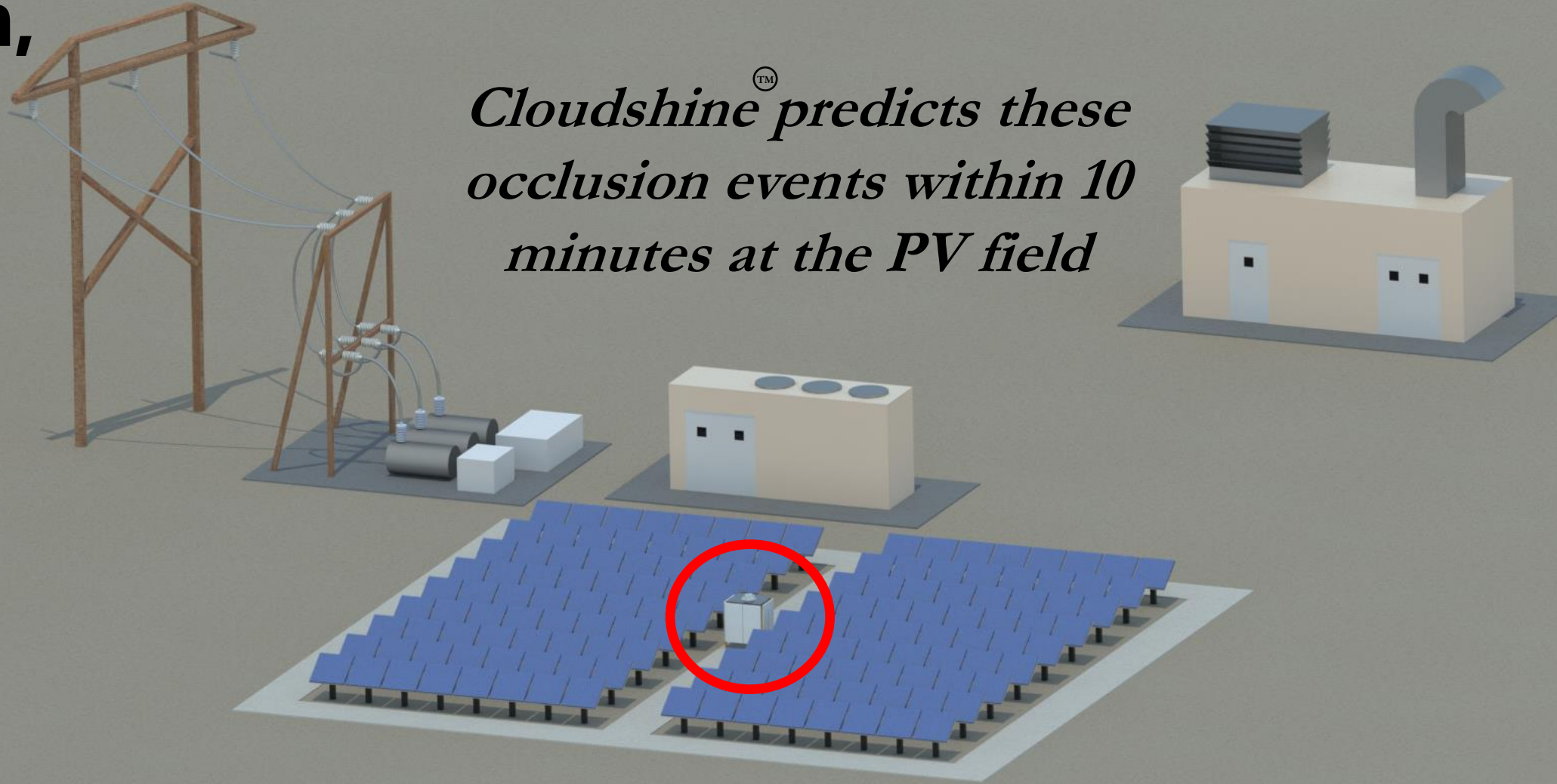

USPTO: US9921339, US10345486

As clouds approach, solar power will turn off.

Forecasting

CloudshineTM predicts these occlusion events within 10 minutes at the PV field

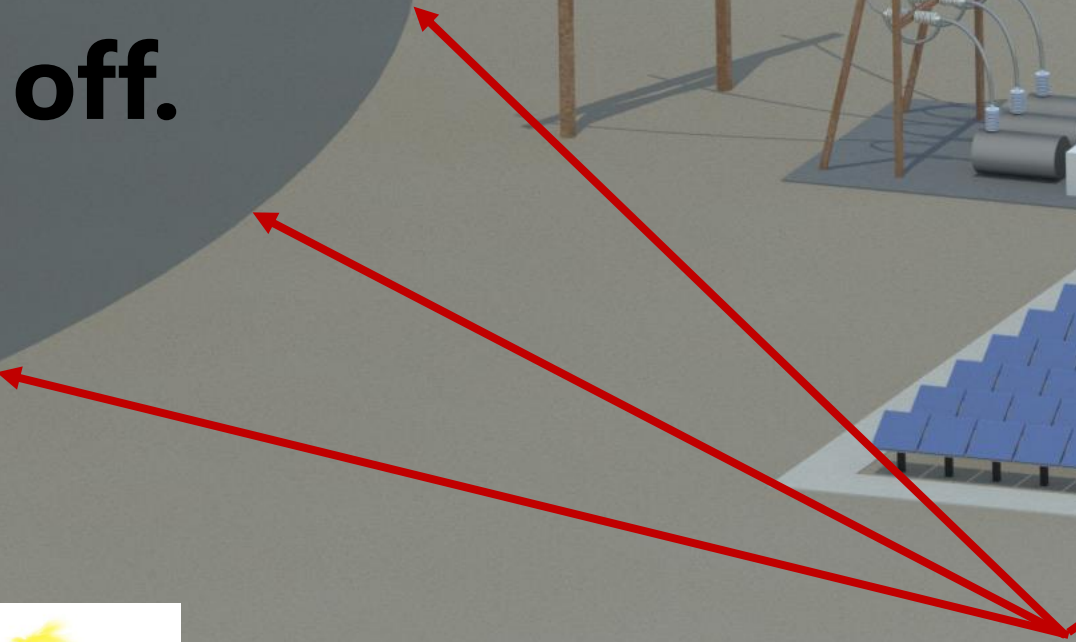
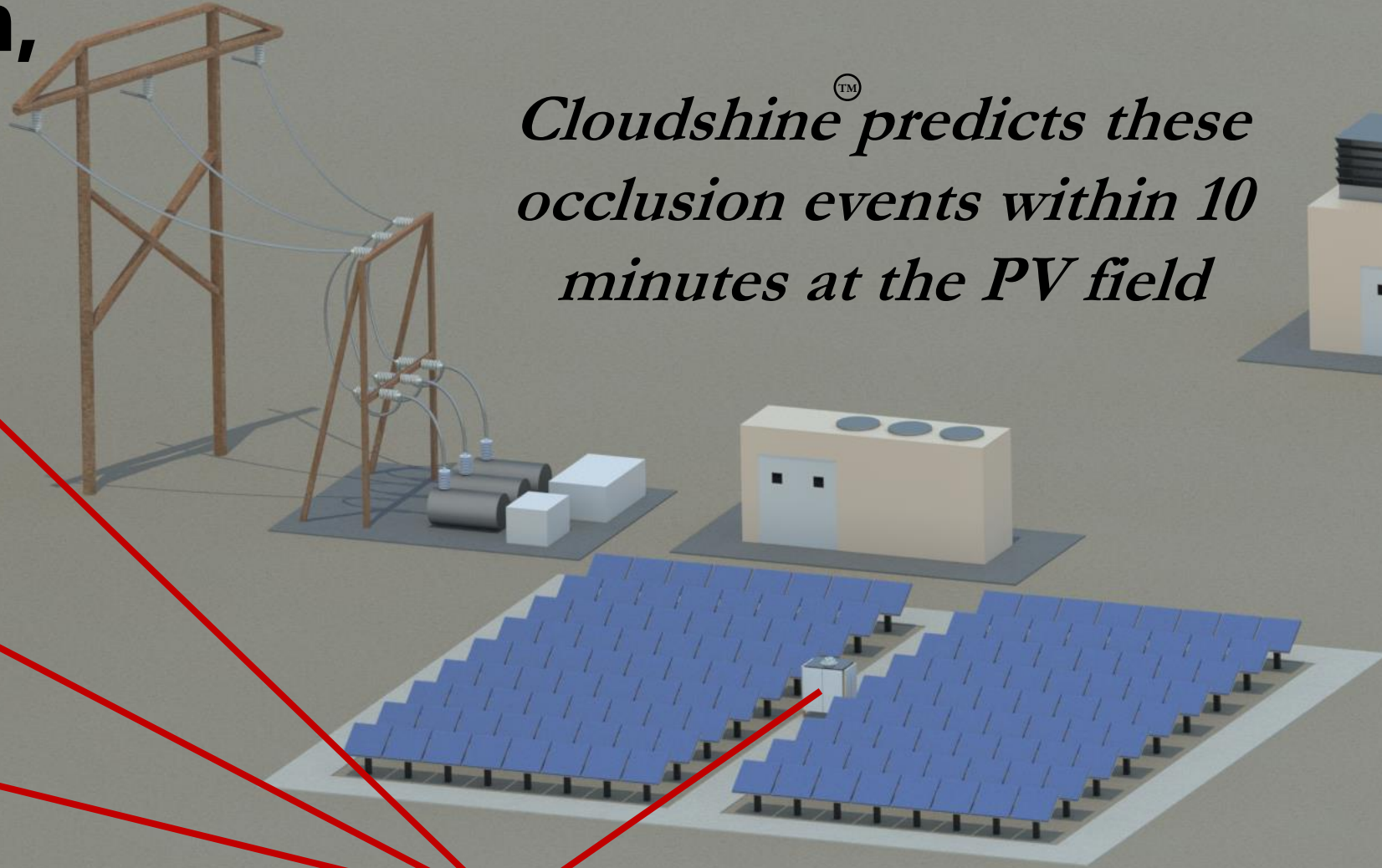

*US9921339,
US10345486*



As clouds approach, solar power will turn off.

Forecasting

CloudshineTM predicts these occlusion events within 10 minutes at the PV field

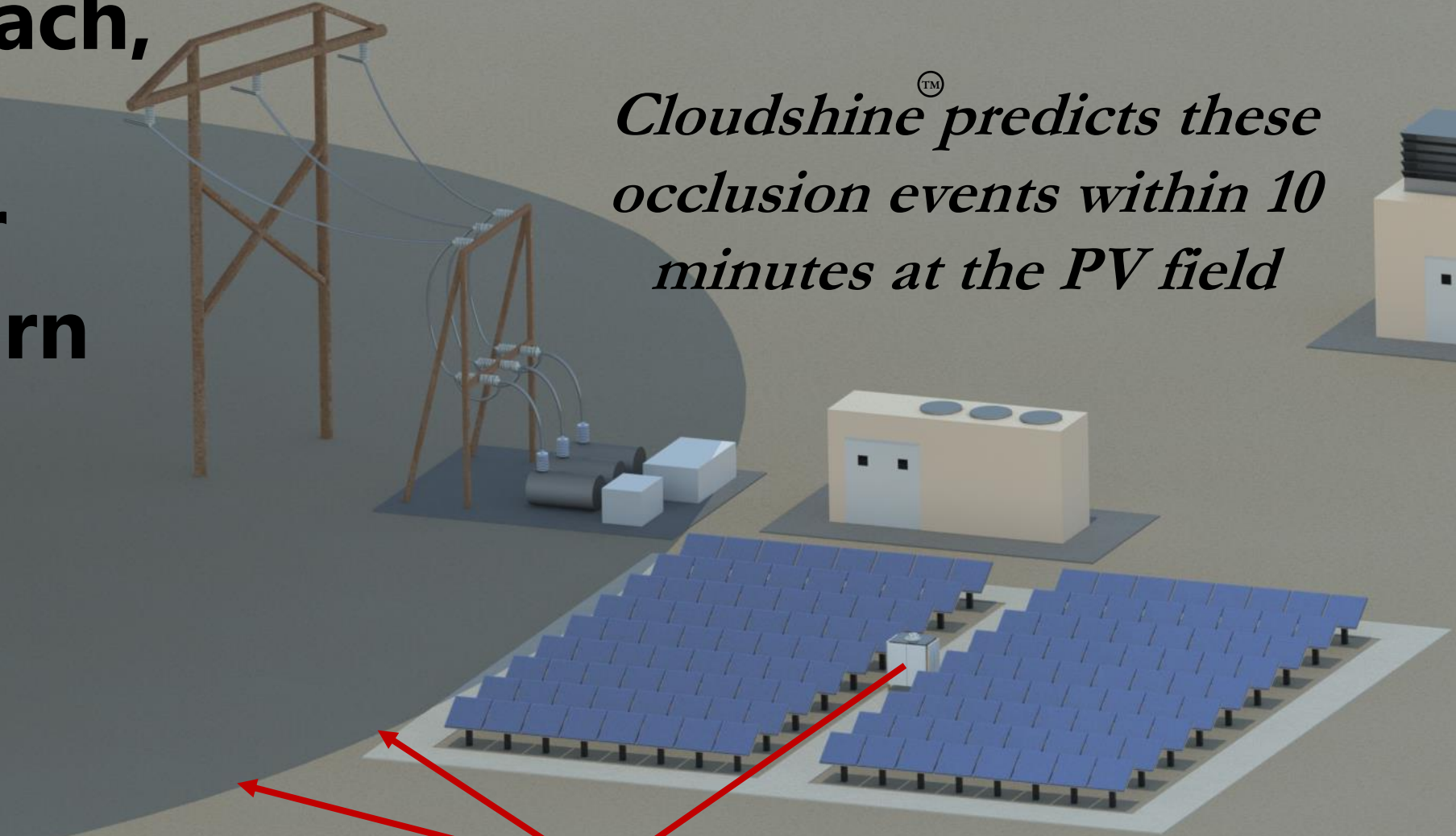
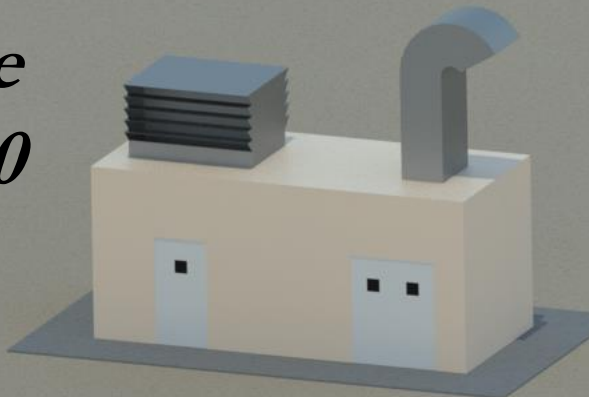

*US9921339,
US10345486*

...so utilities can prepare a response, proactively.



As clouds approach, solar power will turn off.

Forecasting

CloudshineTM predicts these occlusion events within 10 minutes at the PV field

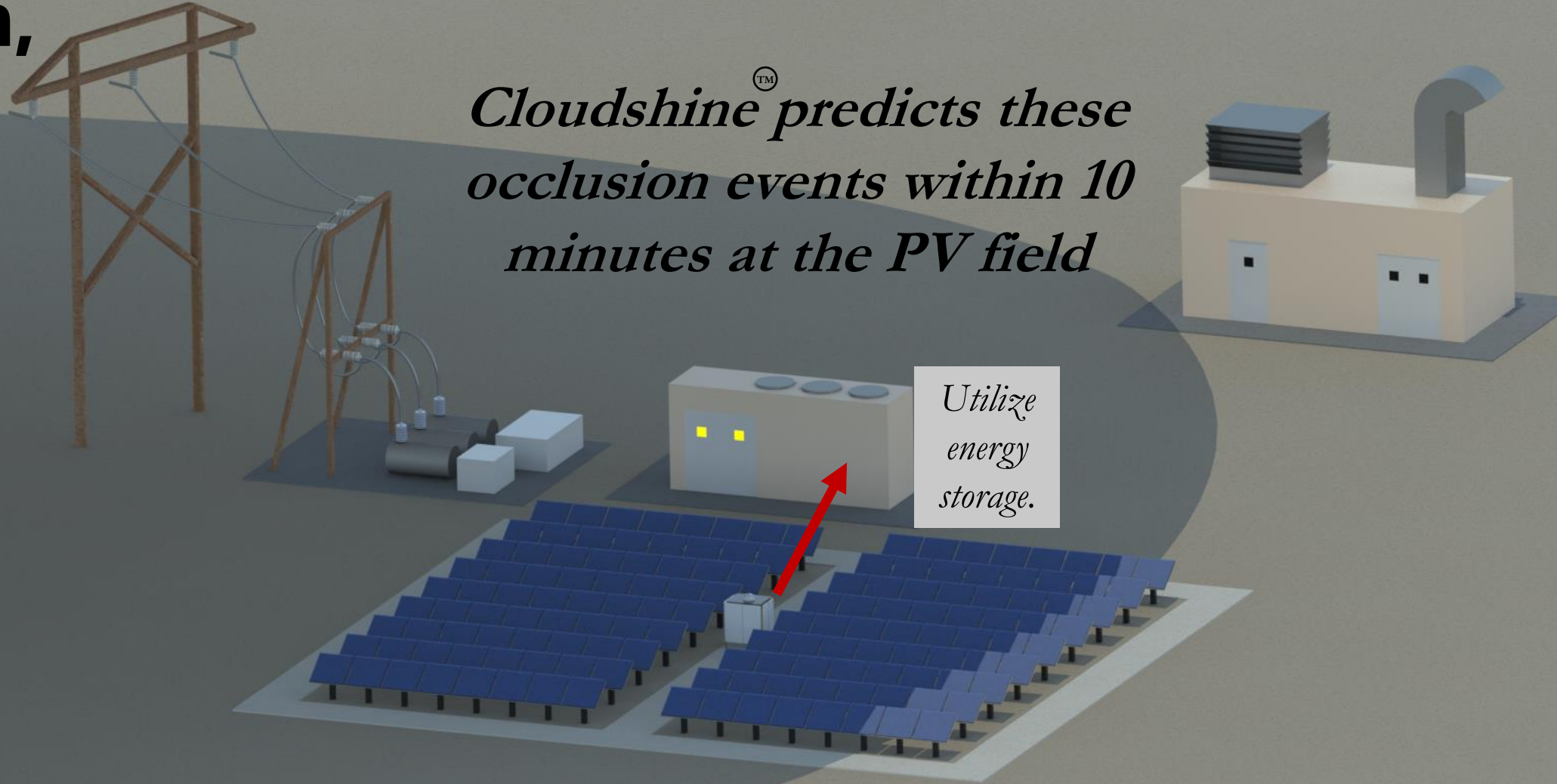

Utilize energy storage.

*US9921339,
US10345486*

...so utilities can prepare a response, proactively.



Flywheel Components

- Fast acting, High Power, Low Energy -> Perfect for smoothing
- Batteries are too SLOW
- MASSIVE resurgence in Flywheel Companies
- Natural Partner to PV smoothing technology

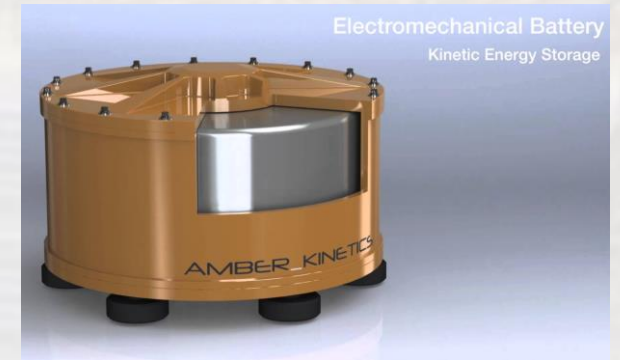

Smoothing needs this.
Lots of Energy FAST!

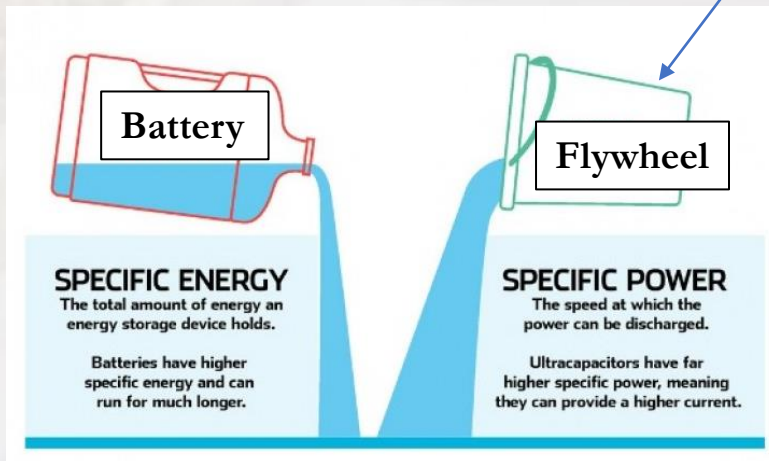

Hungry Market

- Approximately 400,000 Distributed PV Farms in California
- \$500B market in California
- California is mandating legislation that this product addresses...

California Energy Commission – Tracking Progress

frequency, time-of-use bill management, such as pumped storage can help meet requirements for resource flexibility.⁴

Working together to implement rules and storage systems can provide.

United States. In compliance with Assembly Bill 21), the CPUC set targets for them to procure more than 1.3 GW of transmission-connected, storage systems. As of early August 2018, the CPUC had approved to procure almost 1,500 MW of storage capacity (see Table 1.) Projects procured under the Storage Procurement

Hyperdrive

World's Biggest Battery Project Comes to Power-Hungry California

By Brian Eckhouse
August 19, 2020, 10:00 AM MDT

- ▶ LS Power's 230-megawatt project commissioned near San Diego
- ▶ Lack of energy storage has strained power grid amid heatwave

LIVE ON BLOOMBERG
Watch Live TV >
Bloomberg Television
Listen to Live Radio >

LISTEN TO ARTICLE ▶ 1:17 The world's biggest battery-storage system is now in operation in California.

SHARE THIS ARTICLE The 230-megawatt project in San Diego county is significantly bigger than a Tesla Inc. system in

Pacific Gas and Electric	Target	On-Line Storage	Approved, Some Are in Progress	Pending Approval	TOTAL PROCURED

PNM Solar Storage System a 'First'

BY MICHAEL HARTRANFT / JOURNAL STAFF WRITER
Published: Tuesday, September 20th, 2011 at 12:05am
Updated: Monday, September 19th, 2011 at 11:05pm







[skip to content](#) [home](#) [accessibility](#) [FAQ](#) [feedback](#) [sitemap](#) [login](#)

Home | Bill Information | California Law | Publications | Other Resources | My Subscriptions | My Favorites

Bill Information >> Bill Search >> Text

AB-1720 Energy: long-duration energy storage: procurement. (2019-2020)

Text | Votes | History | Bill Analysis | Today's Law As Amended | Compare Versions | Status | Comments To Author

SHARE THIS:  

AMENDED IN SENATE
AMENDED IN SENATE
AMENDED IN ASSEMBLY



CALIFORNIA LEGISLATURE—2019

ASSEMBLY BILL

Introduced by Assembly

February 22, 2019

California Releases Report Charting Path to 100 Percent Clean Electricity

For Immediate Release: March 15, 2021

- California will need to sustain its expansion of clean electricity generation capacity at a record-breaking rate for the next 25 years. On average, the state may need to build up to 6 gigawatts (GW) of new renewable and storage resources annually. By comparison over the last decade, the state has built on average 1 GW of utility solar and 300 megawatts (MW) of wind per year. Over the next three years, electricity providers regulated by the CPUC will add another 8 GW of clean energy resources.



Timeline

TIMELINE for cost effective solar PV Energy Smoothing Solution with Solar Irradiance Micro-Forecasting

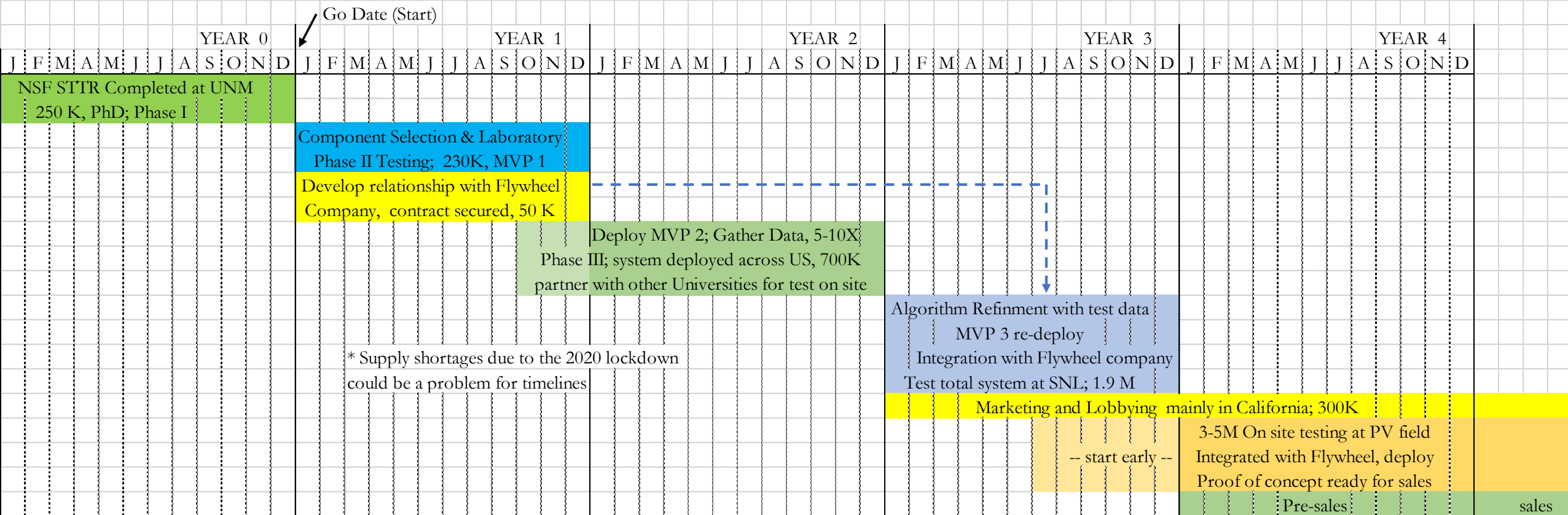

Phases of Investment:

II: 270K; III: 700K; IV: 2.2M; V: 3-5M;



Revenue & Distribution

- Manufacturing secured with local Albuquerque vendors.
(completed)
- Direct Leases from factory.
- Work with Flywheel Company to deploy services and updates.
- Possible Licensing of manufacturing, (not required.)
- Established ArmaTech LLC, 2019



Forecasting TEAM

Prof. Anthony Menicucci

Founder



Prof. Andrea Mammoli

Co-Inventor/Advisor



Prof. Thomas Caudell

Co-Inventor/Advisor



New Hire:
Marketing & Lobbying
California Specialist

Cloudshine[™]
New Hire

New Hires Technical, 2-3X:

UNM engineer interns to FTE





ArmaTech LLC

Anthony Menicucci, PhD. (Dr. A); amen@unm.edu;
<https://armatech.us/>; anthony@armatech.us

Partners and Potential Customers

