

•16–129. Determine the angular acceleration of link AB if link CD has the angular velocity and angular deceleration shown.

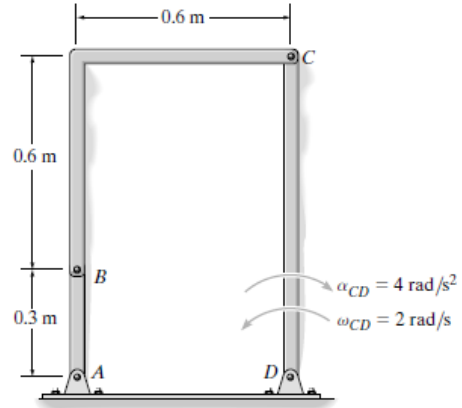

IC is at ∞ , thus

$$\omega_{BC} = 0$$

$$v_B = v_C = (0.9)(2) = 1.8 \text{ m/s}$$

$$(a_C)_n = (2)^2(0.9) = 3.6 \text{ m/s}^2 \downarrow$$

$$(a_C)_t = 4(0.9) = 3.6 \text{ m/s}^2 \rightarrow$$

$$(a_B)_n = \frac{(1.8)^2}{0.3} = 10.8 \text{ m/s}^2 \downarrow$$

$$\mathbf{a}_B = \mathbf{a}_C + \alpha_{BC} \times \mathbf{r}_{B/C} - \omega_{BC}^2 \mathbf{r}_{B/C}$$

$$(a_B)_t \mathbf{i} - 10.8 \mathbf{j} = 3.6 \mathbf{i} - 3.6 \mathbf{j} + (\alpha_{BC} \mathbf{k}) \times (-0.6 \mathbf{i} - 0.6 \mathbf{j}) - 0$$

$$(\pm) \quad (a_B)_t = 3.6 + 0.6 \alpha_{BC}$$

$$(+\uparrow) \quad -10.8 = -3.6 - 0.6 \alpha_{BC}$$

$$\alpha_{BC} = 12 \text{ rad/s}^2$$

$$(a_B)_t = 10.8 \text{ m/s}^2$$

$$\alpha_{AB} = \frac{10.8}{0.3} = 36 \text{ rad/s}^2 \curvearrowright$$

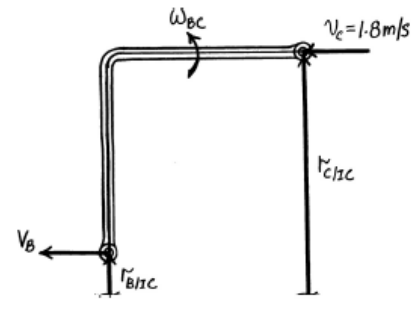

Ans.

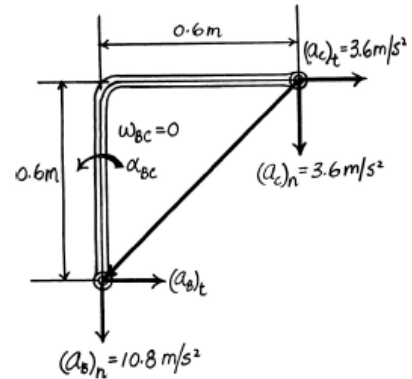

16-131. Gear A rotates counterclockwise with a constant angular velocity of $\omega_A = 10$ rad/s, while arm DE rotates clockwise with an angular velocity of $\omega_{DE} = 6$ rad/s and an angular acceleration of $\alpha_{DE} = 3$ rad/s². Determine the angular acceleration of gear B at the instant shown.

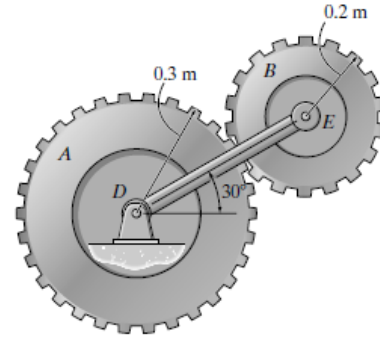

Angular Velocity: Arm DE and gear A rotate about a fixed axis, Figs. a and b . Thus,

$$v_E = \omega_{DE} r_E = 6(0.5) = 3 \text{ m/s}$$

$$v_F = \omega_A r_F = 10(0.3) = 3 \text{ m/s}$$

The location of the IC for gear B is indicated in Fig. c . Thus,

$$r_{E/IC} = r_{F/IC} = 0.1 \text{ m}$$

Then,

$$\omega_B = \frac{v_E}{r_{E/IC}} = \frac{3}{0.1} = 30 \text{ rad/s}$$

Acceleration and Angular Acceleration: Since arm DE rotates about a fixed axis, Fig. c , then

$$\begin{aligned} \mathbf{a}_E &= \alpha_{DE} \times \mathbf{r}_E - \omega_{DE}^2 \mathbf{r}_E \\ &= (-3\mathbf{k}) \times (0.5 \cos 30^\circ \mathbf{i} + 0.5 \sin 30^\circ \mathbf{j}) - 6^2 (0.5 \cos 30^\circ \mathbf{i} + 0.5 \sin 30^\circ \mathbf{j}) \\ &= [-14.84\mathbf{i} - 10.30\mathbf{j}] \text{ m/s}^2 \end{aligned}$$

Using these results and applying the acceleration equation to points E and F of gear B , Fig. e ,

$$\mathbf{a}_F = \mathbf{a}_E + \alpha_B \times \mathbf{r}_{F/E} - \omega_B^2 \mathbf{r}_{F/E}$$

$$\begin{aligned} a_F \cos 30^\circ \mathbf{i} + a_F \sin 30^\circ \mathbf{j} &= (-14.84\mathbf{i} - 10.30\mathbf{j}) + (-\alpha_B \mathbf{k}) \times \\ &\quad (-0.2 \cos 30^\circ \mathbf{i} - 0.2 \sin 30^\circ \mathbf{j}) - 30^2 (-0.2 \cos 30^\circ \mathbf{i} - 0.2 \sin 30^\circ \mathbf{j}) \end{aligned}$$

$$0.8660a_F \mathbf{i} + 0.5a_F \mathbf{j} = (141.05 - 0.1\alpha_B)\mathbf{i} + (79.70 + 0.1732\alpha_B)\mathbf{j}$$

Equating the \mathbf{i} and \mathbf{j} components yields

$$0.8660a_F = 141.05 - 0.1\alpha_B$$

$$0.5a_F = 79.70 + 0.1732\alpha_B$$

$$a_F = 162 \text{ m/s}^2$$

$$\alpha_B = 7.5 \text{ rad/s}^2$$

Ans.

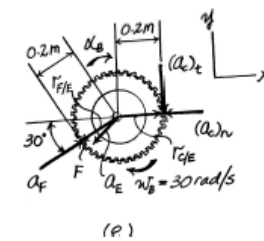
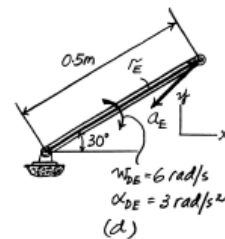
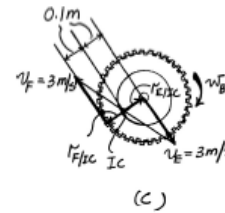
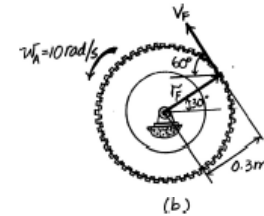
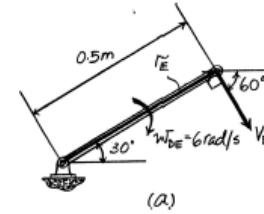

•16–137. Ball C moves with a speed of 3 m/s, which is increasing at a constant rate of 1.5 m/s², both measured relative to the circular plate and directed as shown. At the same instant the plate rotates with the angular velocity and angular acceleration shown. Determine the velocity and acceleration of the ball at this instant.

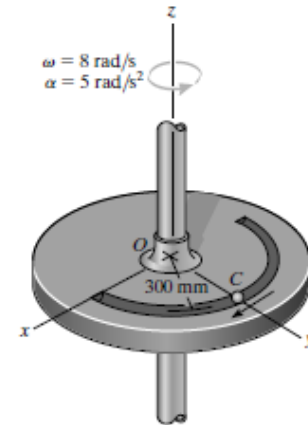

Reference Frames: The xyz rotating reference frame is attached to the plate and coincides with the fixed reference frame XYZ at the instant considered, Fig. a . Thus, the motion of the xyz frame with respect to the XYZ frame is

$$\mathbf{v}_O = \mathbf{a}_O = \mathbf{0} \quad \boldsymbol{\omega} = [8\mathbf{k}] \text{ rad/s} \quad \dot{\boldsymbol{\omega}} = \boldsymbol{\alpha} = [5\mathbf{k}] \text{ rad/s}^2$$

For the motion of ball C with respect to the xyz frame, we have

$$\mathbf{r}_{C/O} = [0.3\mathbf{j}] \text{ m}$$

$$(\mathbf{v}_{rel})_{xyz} = [3\mathbf{i}] \text{ m/s}$$

The normal component of $(\mathbf{a}_{rel})_{xyz}$ is $[(\mathbf{a}_{rel})_{xyz}]_n = \frac{(v_{rel})_{xyz}^2}{\rho} = \frac{3^2}{0.3} = 30 \text{ m/s}^2$.

Thus,

$$(\mathbf{a}_{rel})_{xyz} = [1.5\mathbf{i} - 30\mathbf{j}] \text{ m/s}^2$$

Velocity: Applying the relative velocity equation,

$$\begin{aligned} \mathbf{v}_C &= \mathbf{v}_O + \boldsymbol{\omega} \times \mathbf{r}_{C/O} + (\mathbf{v}_{rel})_{xyz} \\ &= \mathbf{0} + (8\mathbf{k}) \times (0.3\mathbf{j}) + (3\mathbf{i}) \\ &= [0.6\mathbf{i}] \text{ m/s} \end{aligned}$$

Ans.

Acceleration: Applying the relative acceleration equation.

$$\begin{aligned} \mathbf{a}_C &= \mathbf{a}_O + \dot{\boldsymbol{\omega}} \times \mathbf{r}_{C/O} + \boldsymbol{\omega} \times (\boldsymbol{\omega} \times \mathbf{r}_{C/O}) + 2\boldsymbol{\omega} \times (\mathbf{v}_{rel})_{xyz} + (\mathbf{a}_{rel})_{xyz} \\ &= \mathbf{0} + (5\mathbf{k}) \times (0.3\mathbf{j}) + (8\mathbf{k}) \times [(8\mathbf{k}) \times (0.3\mathbf{j})] + 2(8\mathbf{k}) \times (3\mathbf{i}) + (1.5\mathbf{i} - 30\mathbf{j}) \\ &= [-1.2\mathbf{j}] \text{ m/s}^2 \end{aligned}$$

Ans.

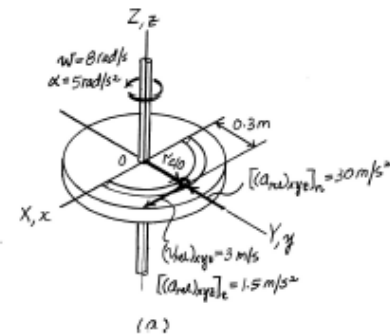

•16-145. The disk rolls without slipping and at a given instant has the angular motion shown. Determine the angular velocity and angular acceleration of the slotted link BC at this instant. The peg at A is fixed to the disk.

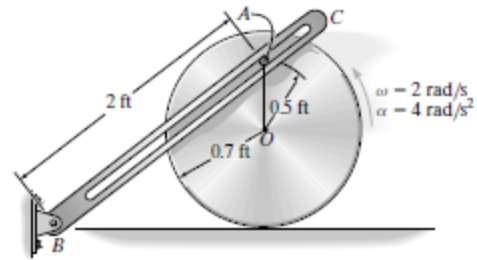

$$\mathbf{v}_A = -(1.2)(2)\mathbf{i} = -2.4\mathbf{i} \text{ ft/s}$$

$$\mathbf{a}_A = \mathbf{a}_O + \alpha \times \mathbf{r}_{A/O} - \omega^2 \mathbf{r}_{A/O}$$

$$\mathbf{a}_A = -4(0.7)\mathbf{i} + (4\mathbf{k}) \times (0.5\mathbf{j}) - (2)^2(0.5\mathbf{j})$$

$$\mathbf{a}_A = -4.8\mathbf{i} - 2\mathbf{j}$$

$$\mathbf{v}_A = \mathbf{v}_B + \Omega \times \mathbf{r}_{A/B} + (\mathbf{v}_{A/B})_{xyz}$$

$$-2.4\mathbf{i} = \mathbf{0} + (\omega_{BC}\mathbf{k}) \times (1.6\mathbf{i} + 1.2\mathbf{j}) + v_{A/B}\left(\frac{4}{5}\mathbf{i}\right) + v_{A/B}\left(\frac{3}{5}\mathbf{j}\right)$$

$$-2.4\mathbf{i} = 1.6\omega_{BC}\mathbf{j} - 1.2\omega_{BC}\mathbf{i} + 0.8v_{A/B}\mathbf{i} + 0.6v_{A/B}\mathbf{j}$$

$$-2.4 = -1.2\omega_{BC} + 0.8v_{A/B}$$

$$0 = 1.6\omega_{BC} + 0.6v_{A/B}$$

Solving,

$$\omega_{BC} = 0.720 \text{ rad/s} \quad \curvearrowright$$

$$v_{A/B} = -1.92 \text{ ft/s}$$

$$\mathbf{a}_A = \mathbf{a}_B + \Omega \times \mathbf{r}_{A/B} + \Omega \times (\Omega \times \mathbf{r}_{A/B}) + 2\Omega \times (\mathbf{v}_{A/B})_{xyz} + (\mathbf{a}_{A/B})_{xyz}$$

$$-4.8\mathbf{i} - 2\mathbf{j} = \mathbf{0} + (\alpha_{BC}\mathbf{k}) \times (1.6\mathbf{i} + 1.2\mathbf{j}) + (0.72\mathbf{k}) \times (0.72\mathbf{k}) \times (1.6\mathbf{i} + 1.2\mathbf{j})$$

$$+ 2(0.72\mathbf{k}) \times [-(0.8)(1.92)\mathbf{i} - 0.6(1.92)\mathbf{j}] + 0.8a_{B/A}\mathbf{i} + 0.6a_{B/A}\mathbf{j}$$

$$-4.8\mathbf{i} - 2\mathbf{j} = 1.6\alpha_{BC}\mathbf{j} - 1.2\alpha_{BC}\mathbf{i} - 0.8294\mathbf{i} - 0.6221\mathbf{j} - 2.2118\mathbf{j} + 1.6589\mathbf{i} + 0.8a_{B/A}\mathbf{i} + 0.6a_{B/A}\mathbf{j}$$

$$-4.8 = -1.2\alpha_{BC} - 0.8294 + 1.6589 + 0.8a_{B/A}$$

$$-2 = 1.6\alpha_{BC} - 0.6221 - 2.2118 + 0.6a_{B/A}$$

Solving,

$$\alpha_{BC} = 2.02 \text{ rad/s}^2 \quad \curvearrowright$$

$$a_{B/A} = -4.00 \text{ ft/s}^2$$

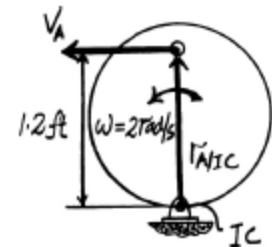

Ans.

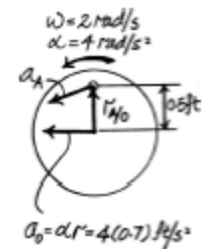

$$a_O = a r = 4(0.7) \text{ ft/s}^2$$

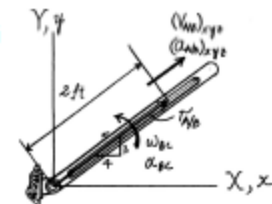

Ans.

16–150. At the instant shown, car *A* travels with a speed of 25 m/s, which is decreasing at a constant rate of 2 m/s², while car *B* travels with a speed of 15 m/s, which is increasing at a constant rate of 2 m/s². Determine the velocity and acceleration of car *A* with respect to car *B*.

Reference Frames: The *xyz* rotating reference frame is attached to car *B* and coincides with the *XYZ* fixed reference frame at the instant considered, Fig. *a*. Since car *B* moves along the circular road, its normal component of acceleration is $(a_B)_n = \frac{v_B^2}{\rho} = \frac{15^2}{250} = 0.9 \text{ m/s}^2$. Thus, the motion of car *B* with respect to the *XYZ* frame is

$$\mathbf{v}_B = [-15\mathbf{i}] \text{ m/s}$$

$$\mathbf{a}_B = [-2\mathbf{i} + 0.9\mathbf{j}] \text{ m/s}^2$$

Also, the angular velocity and angular acceleration of the *xyz* frame with respect to the *XYZ* frame is

$$\omega = \frac{v_B}{\rho} = \frac{15}{250} = 0.06 \text{ rad/s} \quad \omega = [-0.06\mathbf{k}] \text{ rad/s}$$

$$\dot{\omega} = \frac{(a_B)_t}{\rho} = \frac{2}{250} = 0.008 \text{ rad/s}^2 \quad \dot{\omega} = [-0.008\mathbf{k}] \text{ rad/s}^2$$

The velocity of car *A* with respect to the *XYZ* reference frame is

$$\mathbf{v}_A = [25\mathbf{j}] \text{ m/s} \quad \mathbf{a}_A = [-2\mathbf{j}] \text{ m/s}^2$$

From the geometry shown in Fig. *a*,

$$\mathbf{r}_{A/B} = [-200\mathbf{j}] \text{ m}$$

Velocity: Applying the relative velocity equation,

$$\mathbf{v}_A = \mathbf{v}_B + \omega \times \mathbf{r}_{A/B} + (\mathbf{v}_{rel})_{xyz}$$

$$25\mathbf{j} = -15\mathbf{i} + (-0.06\mathbf{k}) \times (-200\mathbf{j}) + (\mathbf{v}_{rel})_{xyz}$$

$$25\mathbf{j} = -27\mathbf{i} + (\mathbf{v}_{rel})_{xyz}$$

$$(\mathbf{v}_{rel})_{xyz} = [27\mathbf{i} + 25\mathbf{j}] \text{ m/s} \quad \text{Ans.}$$

Acceleration: Applying the relative acceleration equation,

$$\mathbf{a}_A = \mathbf{a}_B + \dot{\omega} \times \mathbf{r}_{A/B} + \omega \times (\omega \times \mathbf{r}_{A/B}) + 2\omega \times (\mathbf{v}_{rel})_{xyz} + (\mathbf{a}_{rel})_{xyz}$$

$$-2\mathbf{j} = (-2\mathbf{i} + 0.9\mathbf{j}) + (-0.008\mathbf{k}) \times (-200\mathbf{j}) + (-0.06\mathbf{k}) \times [(-0.06\mathbf{k}) \times (-200\mathbf{j})] + 2(-0.06\mathbf{k}) \times (27\mathbf{i} + 25\mathbf{j}) + (\mathbf{a}_{rel})_{xyz}$$

$$-2\mathbf{j} = -0.6\mathbf{i} - 1.62\mathbf{j} + (\mathbf{a}_{rel})_{xyz}$$

$$(\mathbf{a}_{rel})_{xyz} = [0.6\mathbf{i} - 0.38\mathbf{j}] \text{ m/s}^2 \quad \text{Ans.}$$

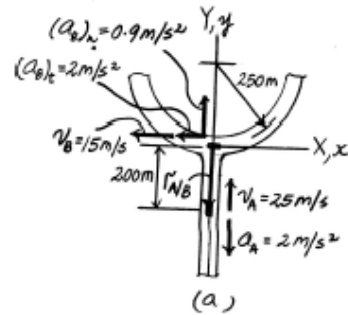
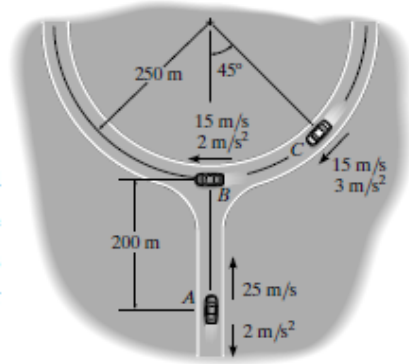

•17-13. If the large ring, small ring and each of the spokes weigh 100 lb, 15 lb, and 20 lb, respectively, determine the mass moment of inertia of the wheel about an axis perpendicular to the page and passing through point A .

Composite Parts: The wheel can be subdivided into the segments shown in Fig. a . The spokes which have a length of $(4 - 1) = 3$ ft and a center of mass located at a distance of $(1 + \frac{3}{2})$ ft = 2.5 ft from point O can be grouped as segment (2).

Mass Moment of Inertia: First, we will compute the mass moment of inertia of the wheel about an axis perpendicular to the page and passing through point O .

$$I_O = \left(\frac{100}{32.2}\right)(4^2) + 8\left[\frac{1}{12}\left(\frac{20}{32.2}\right)(3^2) + \left(\frac{20}{32.2}\right)(2.5^2)\right] + \left(\frac{15}{32.2}\right)(1^2)$$

$$= 84.94 \text{ slug} \cdot \text{ft}^2$$

The mass moment of inertia of the wheel about an axis perpendicular to the page and passing through point A can be found using the parallel-axis theorem

$I_A = I_O + md^2$, where $m = \frac{100}{32.2} + 8\left(\frac{20}{32.2}\right) + \frac{15}{32.2} = 8.5404$ slug and $d = 4$ ft. Thus,

$$I_A = 84.94 + 8.5404(4^2) = 221.58 \text{ slug} \cdot \text{ft}^2 = 222 \text{ slug} \cdot \text{ft}^2 \quad \text{Ans.}$$

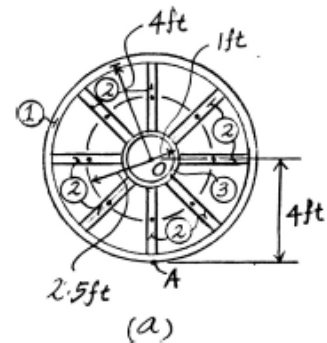
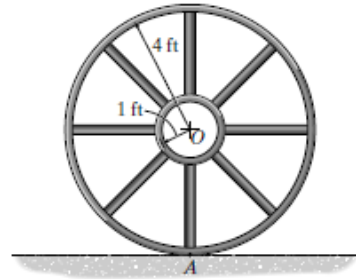

*17-28. The jet aircraft has a mass of 22 Mg and a center of mass at G . If a towing cable is attached to the upper portion of the nose wheel and exerts a force of $T = 400$ N as shown, determine the acceleration of the plane and the normal reactions on the nose wheel and each of the two wing wheels located at B . Neglect the lifting force of the wings and the mass of the wheels.

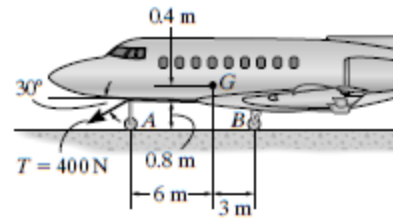

$$\leftarrow \Sigma F_x = m(a_G)_x; \quad 400 \cos 30^\circ = 22(10^3) a_G$$

$$a_G = 0.01575 \text{ m/s}^2 = 0.0157 \text{ m/s}^2 \quad \text{Ans.}$$

$$\zeta + \Sigma M_A = \Sigma (M_k)_A; \quad 400 \cos 30^\circ (0.8) + 2N_B (9) - 22(10^3) (9.81)(6)$$

$$= 22(10^3)(0.01575)(1.2)$$

$$N_B = 71\,947.70 \text{ N} = 71.9 \text{ kN} \quad \text{Ans.}$$

$$+\uparrow \Sigma F_y = m(a_G)_y; \quad N_A + 2(71\,947.70) - 22(10^3)(9.81) - 400 \sin 30^\circ = 0$$

$$N_A = 72\,124.60 \text{ N} = 72.1 \text{ kN} \quad \text{Ans.}$$

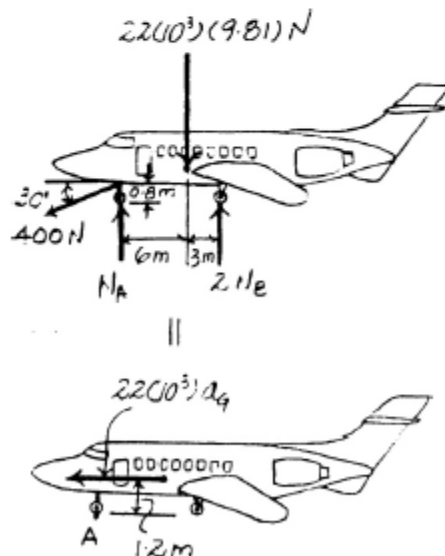

17-22. Determine the mass moment of inertia of the thin plate about an axis perpendicular to the page and passing through point O . The material has a mass per unit area of 20 kg/m^2 .

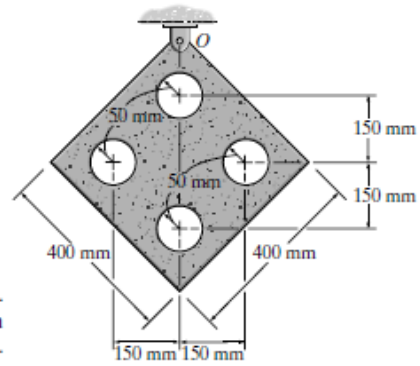

Composite Parts: The plate can be subdivided into the segments shown in Fig. a . Here, the four similar holes of which the perpendicular distances measured from their centers of mass to point C are the same and can be grouped as segment (2). This segment should be considered as a negative part.

Mass Moment of Inertia: The mass of segments (1) and (2) are $m_1 = (0.4)(0.4)(20) = 3.2 \text{ kg}$ and $m_2 = \pi(0.05^2)(20) = 0.05\pi \text{ kg}$, respectively. The mass moment of inertia of the plate about an axis perpendicular to the page and passing through point C is

$$I_C = \frac{1}{12}(3.2)(0.4^2 + 0.4^2) - 4\left[\frac{1}{2}(0.05\pi)(0.05^2) + 0.05\pi(0.15^2)\right]$$

$$= 0.07041 \text{ kg} \cdot \text{m}^2$$

The mass moment of inertia of the wheel about an axis perpendicular to the page and passing through point O can be determined using the parallel-axis theorem $I_O = I_C + md^2$, where $m = m_1 - m_2 = 3.2 - 4(0.05\pi) = 2.5717 \text{ kg}$ and $d = 0.4 \sin 45^\circ \text{ m}$. Thus,

$$I_O = 0.07041 + 2.5717(0.4 \sin 45^\circ)^2 = 0.276 \text{ kg} \cdot \text{m}^2 \quad \text{Ans.}$$

