

### Higher Order Elements

**Linear Strain or Quadratic Triangle**

$$N_1 = L_1(2L_1 - 1)$$

$$N_2 = L_2(2L_2 - 1)$$

$$N_3 = L_3(2L_3 - 1)$$

$$N_4 = 4L_1 L_2$$

$$N_5 = 4L_2 L_3$$

$$N_6 = 4L_1 L_3$$

**Shape Functions**

**Cubic Triangle**

etc.

*Biquadratic*

*Bicubic*

*8-node Serendipity*

*12-node Serendipity*

### PASCAL'S TRIANGLE

1 TRIANGLES

*linear*

QUADRILATERALS

*bilinear*

*biquadratic*

*quadratic*

*cubic*

$$\begin{array}{cccc}
 & & x & y \\
 & & x^2 & xy & y^2 \\
 & x^3 & x^2y & xy^2 & y^3 \\
 x^4 & x^3y & x^2y^2 & xy^3 & y^4
 \end{array}$$

**Chapter 7: Practical Considerations in Modeling**  
 Good reading before you start working in the project

### Three-dimensional solid elements

**Linear Tetrahedron**

$$u(x, y, z) = a + bx + cy + dz$$

same for  $v(x, y, z)$  and  $w(x, y, z)$

**8-Node Trilinear Brick**

$$u(x, y, z) = a + bx + cy + dz + exy + fxz + gyz$$

same for  $v(x, y, z)$  and  $w(x, y, z)$

**h-Method:**  
 Accuracy is improved by refining the mesh, that is adding more elements of the same kind to the analysis.

**p-Method:**  
 The mesh is held fixed and accuracy is improved by raising the order of the interpolating polynomial over the elements.

**Mixed methods:**

- The h- and p-methods can be combined as long as conformality is preserved.
- Elements of different types may also be combined preserving conformality

### ACCURACY COMPARISON EXAMPLES

(a)

(b)

**FIGURE 9-4** Basic triangular element: (a) four-CST and (b) one-LST

Parabolic load = 40 kip (total)

12 in.

48 in.

**FIGURE 9-5** Cantilever beam used to compare the CST and LST elements with a 4 × 16 mesh

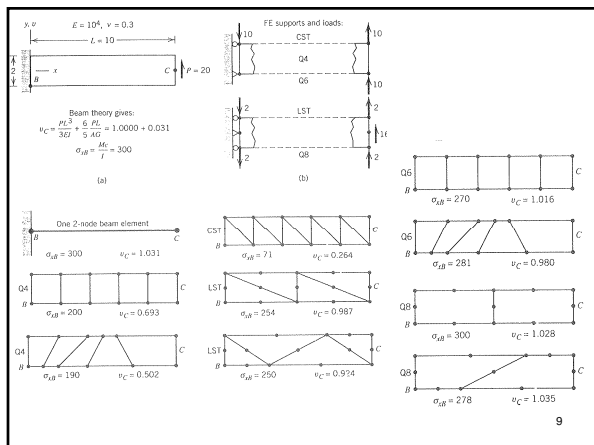
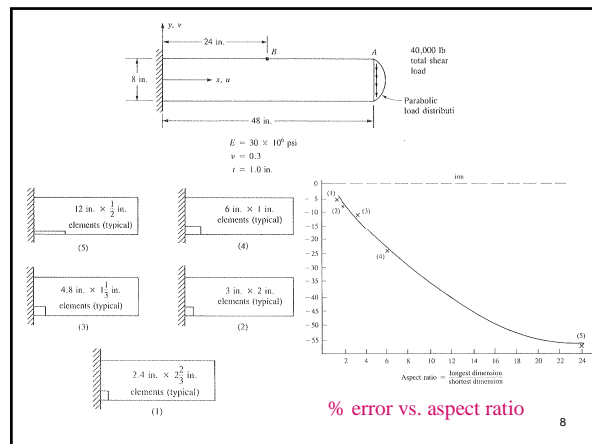
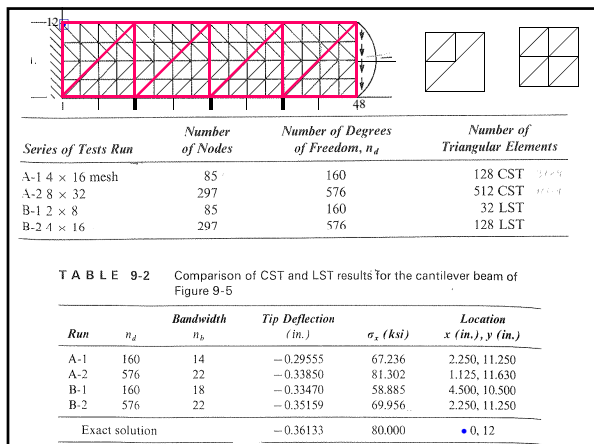

### Convergence rates

Let  $\mathbf{u} = \begin{bmatrix} u(x, y) \\ v(x, y) \end{bmatrix}$  then the error is  $\|\mathbf{u}_{exact} - \mathbf{u}_{FEM}\| = Ch^p$

If the shape functions are polynomials of degree  $n$ , then  $p = n + 1$

- Linear, bilinear, Trilinear  $\Rightarrow O(h^2)$
- Quadratic, Biquadratic, Triquadratic  $\Rightarrow O(h^3)$
- Cubic, Bicubic, Tricubic  $\Rightarrow O(h^4)$
- etc.

For example, if a calculation using a mesh of size  $h$  results in errors  $e_1$  for linear elements,  $e_2$  for quadratic elements and  $e_3$  for cubic elements  
 Using a mesh of size  $h/2$  will result in errors  $e_1/4$  for linear elements,  $e_2/8$  for quadratic elements and  $e_3/16$  for cubic elements

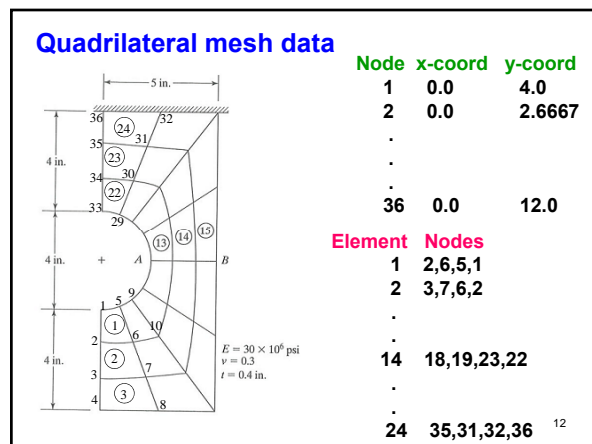
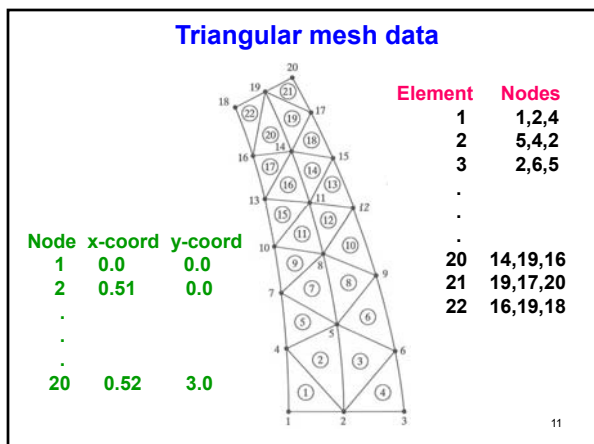

**To find the element stiffness matrices we must evaluate the integrals (plane stress)**

$$k = \int_V \mathbf{B}^T \mathbf{D} \mathbf{B} dV = \int_e \begin{bmatrix} \frac{\partial N_1}{\partial x} & 0 & \frac{\partial N_1}{\partial y} \\ 0 & \frac{\partial N_1}{\partial y} & \frac{\partial N_1}{\partial x} \\ \frac{\partial N_2}{\partial x} & 0 & \frac{\partial N_2}{\partial y} \\ 0 & \frac{\partial N_2}{\partial y} & \frac{\partial N_2}{\partial x} \end{bmatrix} \begin{bmatrix} E' & \nu E' & 0 \\ \nu E' & E' & 0 \\ 0 & 0 & G \end{bmatrix} \begin{bmatrix} \frac{\partial N_1}{\partial x} & 0 & \dots & \frac{\partial N_4}{\partial x} & 0 \\ 0 & \frac{\partial N_1}{\partial y} & \dots & 0 & \frac{\partial N_4}{\partial y} \\ \frac{\partial N_1}{\partial y} & \frac{\partial N_1}{\partial x} & \dots & \frac{\partial N_4}{\partial y} & \frac{\partial N_4}{\partial x} \end{bmatrix} dx dy$$

$$k = \int_e \begin{bmatrix} E' \left( \frac{\partial N_1}{\partial x} \right)^2 + G \left( \frac{\partial N_1}{\partial y} \right)^2 & (\nu E' + G) \frac{\partial N_1}{\partial x} \frac{\partial N_1}{\partial y} & \dots \\ (\nu E' + G) \frac{\partial N_1}{\partial x} \frac{\partial N_1}{\partial y} & E' \left( \frac{\partial N_1}{\partial y} \right)^2 + G \left( \frac{\partial N_1}{\partial x} \right)^2 & \dots \\ \dots & \dots & \dots \end{bmatrix} dx dy$$

13

**So we must integrate expressions of the form**

$$\int_e \frac{\partial N_i}{\partial x} \frac{\partial N_j}{\partial x} dx dy, \int_e \frac{\partial N_i}{\partial y} \frac{\partial N_j}{\partial y} dx dy, \int_e \frac{\partial N_i}{\partial x} \frac{\partial N_j}{\partial y} dx dy$$

**For example, take the rectangular element bilinear element**

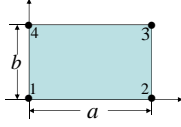

The integral  $\int_e \frac{\partial N_1}{\partial x} \frac{\partial N_2}{\partial x} dx dy$  is

$$\int_e \frac{\partial N_1}{\partial x} \frac{\partial N_2}{\partial x} dx dy = \int_0^a \int_0^b \left( -\frac{1}{a^2} \left( 1 - \frac{2y}{b} + \frac{y^2}{b^2} \right) \right) dx dy = -\frac{b}{3a}$$

$$N_1(x, y) = \left(1 - \frac{x}{a}\right) \left(1 - \frac{y}{b}\right) \quad N_2(x, y) = \frac{x}{a} \left(1 - \frac{y}{b}\right)$$

14

**Now assume that we have a general rectangular element**

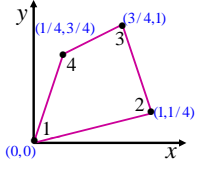

The equations of the sides are  
 side 1-2:  $y = x/4$   
 side 2-3:  $y = (13/4) - 3x$   
 side 3-4:  $y = (1/8) - (3x/2)$   
 side 4-1:  $y = 3x/4$

Let us use the same functions

$$N_1(x, y) = \left(1 - \frac{x}{a}\right) \left(1 - \frac{y}{b}\right) \quad N_2(x, y) = \frac{x}{a} \left(1 - \frac{y}{b}\right)$$

And calculate the integral  $\int_e \frac{\partial N_1}{\partial x} \frac{\partial N_2}{\partial x} dx dy$

15

$$\int_e \frac{\partial N_1}{\partial x} \frac{\partial N_2}{\partial x} dx dy = \int_0^{1/4} \int_{x/4}^{(13/4)-3x} \left( -\frac{1}{a^2} \left( 1 - \frac{2y}{b} + \frac{y^2}{b^2} \right) \right) dy dx +$$

$$\int_{1/4}^{3/4} \int_{x/4}^{(3x/2)-1/8} \left( -\frac{1}{a^2} \left( 1 - \frac{2y}{b} + \frac{y^2}{b^2} \right) \right) dy dx +$$

$$\int_{3/4}^1 \int_{x/4}^{(13/4)-3x} \left( -\frac{1}{a^2} \left( 1 - \frac{2y}{b} + \frac{y^2}{b^2} \right) \right) dy dx$$

**This is very time consuming and if it has to be done for every element it will make the method very difficult to automate (if at all possible) and impractical to use.**

**We also used the shape functions for a rectangular element.**

16

**For a general rectangular elements it is not possible to find bilinear shape functions,**

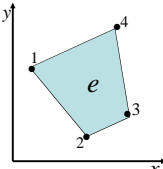

**Consider the parallelogram**

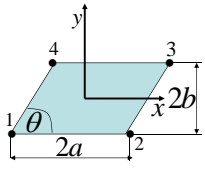

**The shape functions are**

$$N_1(x, y) = \frac{1}{4ab} (a - x + ey)(b - y)$$

$$N_2(x, y) = \frac{1}{4ab} (a + x - ey)(b - y)$$

$$N_3(x, y) = \frac{1}{4ab} (a + x - ey)(b + y)$$

$$N_4(x, y) = \frac{1}{4ab} (a - x + ey)(b + y)$$

**One can construct bilinear functions, but these are not conformal**

17

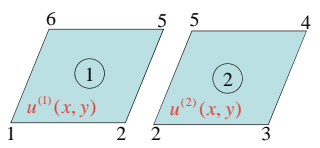

node	x	y
1	0	0
2	1	0
3	2	0
4	2.25	1
5	1.25	1
6	0.25	1

$$u_1(x, y) = a_1 + b_1 x + c_1 y + d_1 xy$$

$$u_2(x, y) = a_2 + b_2 x + c_2 y + d_2 xy$$

$$u^{(1)}(x, y) = (1 - x - y + xy)u_1 + (x - xy)u_2 + (xy - \frac{y}{4})u_5 + (\frac{5y}{4} - xy)u_6$$

$$u^{(2)}(x, y) = (2 - x - 2y + xy)u_2 + (x + y - xy - 1)u_3 + (xy - \frac{5y}{4})u_4 + (xy - \frac{y}{4})u_5$$

The line between nodes 2 and 5 is  $y = 4(x - 1)$

18

Evaluate the displacement fields of each element at a point in the line  $y = 4(x-1)$ , for example take  $x = 1.1$  and  $y = 0.4$ . We get

$$u^{(1)}(1.1, 0.4) = -0.06u_1 + 0.66u_2 + 0.34u_5 + 0.06u_6$$

$$u^{(2)}(1.1, 0.4) = 0.54u_2 + 0.06u_3 - 0.06u_4 + 0.34u_5$$

It is evident that  $u^{(1)}(1.1, 0.4) \neq u^{(2)}(1.1, 0.4)$  unless  $1.2u_2 - 0.06(u_1 + u_3 - u_4 - u_6) = 0$

**Hence the elements are NOT CONFORMAL, the displacement function is not continuous along the elements interface line.**

19

### Isoparametric Transformations

$$\iint_e F(x, y) dx dy = \int_{-1}^1 \int_{-1}^1 G(\xi, \eta) |\mathbf{J}| d\xi d\eta$$

$\mathbf{J}$  is the Jacobian of the transformation  $T$

20

### Quadrilateral Elements

21

It turns out that we can define the inverse of  $T$  very easily using the element shape functions

**This is a "LOCAL" transformation that can be done element by element**

**Global Transformations are impractical or impossible**

22

### 4-Node Bilinear Quadrilateral

The shape functions in the  $\xi$ - $\eta$  plane are:

$$N_1(\xi, \eta) = \frac{1}{4}(1-\xi)(1-\eta)$$

$$N_2(\xi, \eta) = \frac{1}{4}(1+\xi)(1-\eta)$$

$$N_3(\xi, \eta) = \frac{1}{4}(1+\xi)(1+\eta)$$

$$N_4(\xi, \eta) = \frac{1}{4}(1-\xi)(1+\eta)$$

23

In the  $\xi$ - $\eta$  plane we have

$$u(\xi, \eta) = N_1(\xi, \eta)u_1 + N_2(\xi, \eta)u_2 + N_3(\xi, \eta)u_3 + N_4(\xi, \eta)u_4$$

In the x-y plane  $u(x, y) = a + bx + cy + dx^2$

**Substitute the second expression into the first**

$$u(\xi, \eta) = N_1(a + bx_1 + cy_1 + dx_1^2) + N_2(a + bx_2 + cy_2 + dx_2^2) + N_3(a + bx_3 + cy_3 + dx_3^2) + N_4(a + bx_4 + cy_4 + dx_4^2)$$

**Re-arrange**

$$u(\xi, \eta) = u(x, y) = (N_1 + N_2 + N_3 + N_4)a + (N_1x_1 + N_2x_2 + N_3x_3 + N_4x_4)b + (N_1y_1 + N_2y_2 + N_3y_3 + N_4y_4)c + (N_1x_1^2 + N_2x_2^2 + N_3x_3^2 + N_4x_4^2)d$$

**Now equate coefficients with the second equation**

24

$$N_1(\xi, \eta) + N_2(\xi, \eta) + N_3(\xi, \eta) + N_4(\xi, \eta) = 1$$

$$N_1x_1 + N_2x_2 + N_3x_3 + N_4x_4 = x$$

$$N_1y_1 + N_2y_2 + N_3y_3 + N_4y_4 = y$$

$$N_1x_1y_1 + N_2x_2y_2 + N_3x_3y_3 + N_4x_4y_4 = xy$$

25

**Define the transformation**

$$\begin{bmatrix} x \\ y \end{bmatrix} = T \begin{bmatrix} \xi \\ \eta \end{bmatrix} = N_1(\xi, \eta) \begin{bmatrix} x_1 \\ y_1 \end{bmatrix} + N_2(\xi, \eta) \begin{bmatrix} x_2 \\ y_2 \end{bmatrix} + N_3(\xi, \eta) \begin{bmatrix} x_3 \\ y_3 \end{bmatrix} + N_4(\xi, \eta) \begin{bmatrix} x_4 \\ y_4 \end{bmatrix}$$

**Or in general, for an element with n nodes**

$$\begin{bmatrix} x \\ y \end{bmatrix} = T \begin{bmatrix} \xi \\ \eta \end{bmatrix} = \sum_{i=1}^n N_i(\xi, \eta) \begin{bmatrix} x_i \\ y_i \end{bmatrix}$$

**The Isoparametric Transformation:**

1. Requires the shape functions in the  $\xi$ - $\eta$  plane (easy and known)
2. Needs the nodal coordinates in the  $x$ - $y$  plane and the nodal order in the element (these must be known as part of the data)

26

**For the 4-node bilinear element**

$$\begin{bmatrix} x \\ y \end{bmatrix} = T \begin{bmatrix} \xi \\ \eta \end{bmatrix} = \frac{(1-\xi)(1-\eta)}{4} \begin{bmatrix} x_1 \\ y_1 \end{bmatrix} + \frac{(1+\xi)(1-\eta)}{4} \begin{bmatrix} x_2 \\ y_2 \end{bmatrix} + \frac{(1+\xi)(1+\eta)}{4} \begin{bmatrix} x_3 \\ y_3 \end{bmatrix} + \frac{(1-\xi)(1+\eta)}{4} \begin{bmatrix} x_4 \\ y_4 \end{bmatrix}$$

27

**The parent element transforms into the real element:**

1) Nodes in the  $\xi$ - $\eta$  plane transform into the nodes in the  $x$ - $y$  plane

$$\begin{bmatrix} x \\ y \end{bmatrix} = T \begin{bmatrix} \xi \\ \eta \end{bmatrix} = \frac{(1-\xi)(1-\eta)}{4} \begin{bmatrix} x_1 \\ y_1 \end{bmatrix} + \frac{(1+\xi)(1-\eta)}{4} \begin{bmatrix} x_2 \\ y_2 \end{bmatrix} + \frac{(1+\xi)(1+\eta)}{4} \begin{bmatrix} x_3 \\ y_3 \end{bmatrix} + \frac{(1-\xi)(1+\eta)}{4} \begin{bmatrix} x_4 \\ y_4 \end{bmatrix}$$

**Nodes must be numbered counterclockwise**

$$T \begin{bmatrix} -1 \\ -1 \end{bmatrix} = 1 \times \begin{bmatrix} x_1 \\ y_1 \end{bmatrix} + 0 \times \begin{bmatrix} x_2 \\ y_2 \end{bmatrix} + 0 \times \begin{bmatrix} x_3 \\ y_3 \end{bmatrix} + 0 \times \begin{bmatrix} x_4 \\ y_4 \end{bmatrix} = \begin{bmatrix} x_1 \\ y_1 \end{bmatrix} \text{ etc.}$$

28

$$\begin{bmatrix} x \\ y \end{bmatrix} = T \begin{bmatrix} \xi \\ \eta \end{bmatrix} = \frac{(1-\xi)(1-\eta)}{4} \begin{bmatrix} x_1 \\ y_1 \end{bmatrix} + \frac{(1+\xi)(1-\eta)}{4} \begin{bmatrix} x_2 \\ y_2 \end{bmatrix} + \frac{(1+\xi)(1+\eta)}{4} \begin{bmatrix} x_3 \\ y_3 \end{bmatrix} + \frac{(1-\xi)(1+\eta)}{4} \begin{bmatrix} x_4 \\ y_4 \end{bmatrix}$$

**So we have that**

$$T \begin{bmatrix} -1 \\ -1 \end{bmatrix} = \begin{bmatrix} x_1 \\ y_1 \end{bmatrix}, T \begin{bmatrix} 1 \\ -1 \end{bmatrix} = \begin{bmatrix} x_2 \\ y_2 \end{bmatrix}, T \begin{bmatrix} 1 \\ 1 \end{bmatrix} = \begin{bmatrix} x_3 \\ y_3 \end{bmatrix}, T \begin{bmatrix} -1 \\ 1 \end{bmatrix} = \begin{bmatrix} x_4 \\ y_4 \end{bmatrix}$$

**2) The sides transform into the corresponding sides. Let us look at side  $\eta=-1$  that connects nodes 1 and 2 in the  $\xi$ - $\eta$  plane**

$$\begin{bmatrix} x \\ y \end{bmatrix} = T \begin{bmatrix} \xi \\ -1 \end{bmatrix} = \frac{1}{2}(1-\xi) \begin{bmatrix} x_1 \\ y_1 \end{bmatrix} + \frac{1}{2}(1+\xi) \begin{bmatrix} x_2 \\ y_2 \end{bmatrix} + 0 \begin{bmatrix} x_3 \\ y_3 \end{bmatrix} + 0 \begin{bmatrix} x_4 \\ y_4 \end{bmatrix}$$

29

**We can write**

$$x = \frac{1}{2}(1-\xi)x_1 + \frac{1}{2}(1+\xi)x_2$$

$$y = \frac{1}{2}(1-\xi)y_1 + \frac{1}{2}(1+\xi)y_2$$

Find  $\xi$  in terms of  $x$  from  $x = \frac{1}{2}(1-\xi)x_1 + \frac{1}{2}(1+\xi)x_2$

$$\xi = \frac{2x - x_1 - x_2}{x_2 - x_1}$$

Substitute into  $y = \frac{1}{2}(1-\xi)y_1 + \frac{1}{2}(1+\xi)y_2$

$$y = \left( \frac{y_2 - y_1}{x_2 - x_1} \right) x + \frac{x_2y_1 - x_1y_2}{x_2 - x_1}$$

30

Which is the equation of the straight line through the points  $\begin{bmatrix} x_1 \\ y_1 \end{bmatrix}$  and  $\begin{bmatrix} x_2 \\ y_2 \end{bmatrix}$

Hence the transformation is **CONFORMAL**, two adjacent elements coincide along their common side.

3. The point (0,0) maps into the centroid of the quadrilateral

$$T \begin{bmatrix} 0 \\ 0 \end{bmatrix} = \frac{1}{4} \begin{bmatrix} x_1 + x_2 + x_3 + x_4 \\ y_1 + y_2 + y_3 + y_4 \end{bmatrix}$$

Therefore the transformation is 1-1 and onto.

31

**Limitations of the Bilinear Quadrilateral**

All interior angles must be less than 180 degrees otherwise the transformation is singular. That is, There will be a point in the domain where the Jacobian is zero.

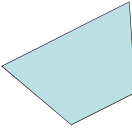

Admissible

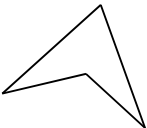

Not admissible

Each quadrilateral element, Quadratic, cubic etc. must be studied individually to determine their limitations as to how much they can be deformed.

32

Irregular meshes can combine Bilinear Quadrilaterals and CST Triangles. Similarly Biquadratic Quadrilaterals can be combined with the quadratic LST Triangle etc.

Higher order elements can be used to match curved boundaries.

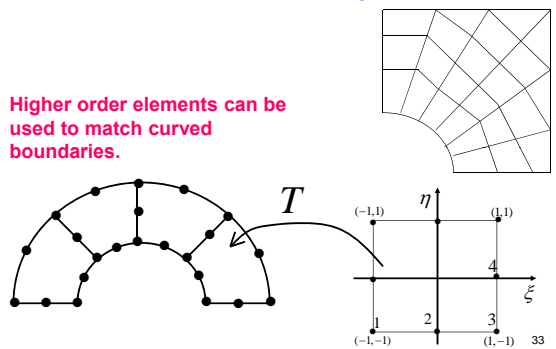

33

**Chain Rule**

$$N_i = N_i(x, y) \quad \frac{\partial N_i}{\partial \xi} = \frac{\partial N_i}{\partial x} \frac{\partial x}{\partial \xi} + \frac{\partial N_i}{\partial y} \frac{\partial y}{\partial \xi}$$

$$x = x(\xi, \eta) \quad \frac{\partial N_i}{\partial \eta} = \frac{\partial N_i}{\partial x} \frac{\partial x}{\partial \eta} + \frac{\partial N_i}{\partial y} \frac{\partial y}{\partial \eta}$$

$$y = y(\xi, \eta)$$

**In Matrix Form**

$$\begin{bmatrix} \frac{\partial N_i}{\partial \xi} \\ \frac{\partial N_i}{\partial \eta} \end{bmatrix} = \begin{bmatrix} \frac{\partial x}{\partial \xi} & \frac{\partial y}{\partial \xi} \\ \frac{\partial x}{\partial \eta} & \frac{\partial y}{\partial \eta} \end{bmatrix} \begin{bmatrix} \frac{\partial N_i}{\partial x} \\ \frac{\partial N_i}{\partial y} \end{bmatrix} \quad \mathbf{J} = \begin{bmatrix} \frac{\partial x}{\partial \xi} & \frac{\partial y}{\partial \xi} \\ \frac{\partial x}{\partial \eta} & \frac{\partial y}{\partial \eta} \end{bmatrix}$$

Jacobian 34

To find the derivatives with respect to x-y we must invert

$$\mathbf{J}^{-1} = \frac{1}{\det \mathbf{J}} \begin{bmatrix} \frac{\partial y}{\partial \eta} & -\frac{\partial y}{\partial \xi} \\ -\frac{\partial x}{\partial \eta} & \frac{\partial x}{\partial \xi} \end{bmatrix} \quad \det \mathbf{J} = \frac{\partial x}{\partial \xi} \frac{\partial y}{\partial \eta} - \frac{\partial x}{\partial \eta} \frac{\partial y}{\partial \xi}$$

Hence in terms of  $\xi$  and  $\eta$  the derivatives are:

$$\frac{\partial N_i}{\partial x} = \frac{1}{\det \mathbf{J}} \left[ \frac{\partial y}{\partial \eta} \frac{\partial N_i}{\partial \xi} - \frac{\partial y}{\partial \xi} \frac{\partial N_i}{\partial \eta} \right]$$

$$\frac{\partial N_i}{\partial y} = \frac{1}{\det \mathbf{J}} \left[ \frac{\partial x}{\partial \xi} \frac{\partial N_i}{\partial \eta} - \frac{\partial x}{\partial \eta} \frac{\partial N_i}{\partial \xi} \right]$$

35

**In terms of shape functions**

$$\frac{\partial x}{\partial \xi} = \sum_{i=1}^4 \frac{\partial N_i}{\partial \xi} x_i, \quad \frac{\partial x}{\partial \eta} = \sum_{i=1}^4 \frac{\partial N_i}{\partial \eta} x_i$$

$$\frac{\partial y}{\partial \xi} = \sum_{i=1}^4 \frac{\partial N_i}{\partial \xi} y_i, \quad \frac{\partial y}{\partial \eta} = \sum_{i=1}^4 \frac{\partial N_i}{\partial \eta} y_i$$

$$\frac{\partial N_1}{\partial \xi} = -\frac{1}{4}(1-\eta), \quad \frac{\partial N_2}{\partial \xi} = \frac{1}{4}(1-\eta), \quad \frac{\partial N_3}{\partial \xi} = \frac{1}{4}(1+\eta), \quad \frac{\partial N_4}{\partial \xi} = -\frac{1}{4}(1+\eta)$$

$$\frac{\partial N_1}{\partial \eta} = -\frac{1}{4}(1-\xi), \quad \frac{\partial N_2}{\partial \eta} = -\frac{1}{4}(1+\xi), \quad \frac{\partial N_3}{\partial \eta} = \frac{1}{4}(1+\xi), \quad \frac{\partial N_4}{\partial \eta} = \frac{1}{4}(1-\xi)$$

$$\det \mathbf{J} = \left( \sum_{i=1}^4 \frac{\partial N_i}{\partial \xi} x_i \right) \left( \sum_{i=1}^4 \frac{\partial N_i}{\partial \eta} y_i \right) - \left( \sum_{i=1}^4 \frac{\partial N_i}{\partial \eta} x_i \right) \left( \sum_{i=1}^4 \frac{\partial N_i}{\partial \xi} y_i \right)$$

36

**Derivatives**

$$\frac{\partial N_i}{\partial x} = \frac{1}{\det \mathbf{J}} \left( \sum_{k=1}^4 \frac{\partial N_k}{\partial \eta} y_k \right) \frac{\partial N_i}{\partial \xi} - \left( \sum_{k=1}^4 \frac{\partial N_k}{\partial \xi} y_k \right) \frac{\partial N_i}{\partial \eta}$$

$$\frac{\partial N_i}{\partial y} = \frac{1}{\det \mathbf{J}} \left( \sum_{k=1}^4 \frac{\partial N_k}{\partial \xi} x_k \right) \frac{\partial N_i}{\partial \eta} - \left( \sum_{k=1}^4 \frac{\partial N_k}{\partial \eta} x_k \right) \frac{\partial N_i}{\partial \xi}$$

- All the expressions are in terms of the shape functions in the  $\xi$ - $\eta$  plane and the nodal coordinates in the x-y plane only.
- We never need to find the shape functions in the x-y plane.

37

**For example**

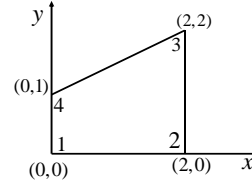

$$\begin{aligned} x_1 &= 0 & y_1 &= 0 \\ x_2 &= 2 & y_2 &= 0 \\ x_3 &= 2 & y_3 &= 2 \\ x_4 &= 0 & y_4 &= 1 \end{aligned}$$

**Isoparametric Transformation**

$$\begin{bmatrix} x \\ y \end{bmatrix} = \frac{(1-\xi)(1-\eta)}{4} \begin{bmatrix} 0 \\ 0 \end{bmatrix} + \frac{(1+\xi)(1-\eta)}{4} \begin{bmatrix} 2 \\ 0 \end{bmatrix} + \frac{(1+\xi)(1+\eta)}{4} \begin{bmatrix} 2 \\ 2 \end{bmatrix} + \frac{(1-\xi)(1+\eta)}{4} \begin{bmatrix} 0 \\ 1 \end{bmatrix}$$

$$x = 1 + \xi$$

$$y = \frac{1}{4}(3 + \xi + 3\eta + \xi\eta)$$

38

**Calculate**

$$\int_{\epsilon} \frac{\partial N_i}{\partial x} \frac{\partial N_i}{\partial y} |\mathbf{J}| dx dy = \int_{-1}^1 \int_{-1}^1 \frac{1}{\det \mathbf{J}} \left[ \left( \sum_{k=1}^4 \frac{\partial N_k}{\partial \eta} y_k \right) \frac{\partial N_i}{\partial \xi} - \left( \sum_{k=1}^4 \frac{\partial N_k}{\partial \xi} y_k \right) \frac{\partial N_i}{\partial \eta} \right] \left[ \left( \sum_{k=1}^4 \frac{\partial N_k}{\partial \xi} x_k \right) \frac{\partial N_i}{\partial \eta} - \left( \sum_{k=1}^4 \frac{\partial N_k}{\partial \eta} x_k \right) \frac{\partial N_i}{\partial \xi} \right] d\xi d\eta$$

First find  $\frac{\partial x}{\partial \xi}$ ,  $\frac{\partial y}{\partial \xi}$ ,  $\frac{\partial}{\partial \eta}$  and  $\frac{\partial y}{\partial \eta}$  for this we need the derivatives of the shape functions

$$\frac{\partial N_1}{\partial \xi} = -\frac{1}{4}(1-\eta), \quad \frac{\partial N_2}{\partial \xi} = \frac{1}{4}(1-\eta), \quad \frac{\partial N_3}{\partial \xi} = \frac{1}{4}(1+\eta), \quad \frac{\partial N_4}{\partial \xi} = \frac{1}{4}(1+\eta)$$

$$\frac{\partial N_1}{\partial \eta} = -\frac{1}{4}(1-\xi), \quad \frac{\partial N_2}{\partial \eta} = -\frac{1}{4}(1+\xi), \quad \frac{\partial N_3}{\partial \eta} = \frac{1}{4}(1+\xi), \quad \frac{\partial N_4}{\partial \eta} = \frac{1}{4}(1-\xi)$$

39

$$\frac{\partial x}{\partial \xi} = \sum_{k=1}^4 \frac{\partial N_k}{\partial \xi} x_k = -\frac{1}{4}(1-\eta) \cdot 0 + \frac{1}{4}(1-\eta) \cdot 2 + \frac{1}{4}(1+\eta) \cdot 2 - \frac{1}{4}(1+\eta) \cdot 0$$

$$\frac{\partial x}{\partial \xi} = 1$$

$$\frac{\partial x}{\partial \eta} = \sum_{k=1}^4 \frac{\partial N_k}{\partial \eta} x_k = -\frac{1}{4}(1-\xi) \cdot 0 - \frac{1}{4}(1+\xi) \cdot 2 + \frac{1}{4}(1+\xi) \cdot 2 + \frac{1}{4}(1-\xi) \cdot 0$$

$$\frac{\partial x}{\partial \eta} = 0$$

$$\frac{\partial y}{\partial \xi} = \sum_{k=1}^4 \frac{\partial N_k}{\partial \xi} y_k = -\frac{1}{4}(1-\eta) \cdot 0 + \frac{1}{4}(1-\eta) \cdot 0 + \frac{1}{4}(1+\eta) \cdot 2 - \frac{1}{4}(1+\eta) \cdot 1$$

$$\frac{\partial y}{\partial \xi} = \frac{1}{4}(1+\eta)$$

$$\frac{\partial y}{\partial \eta} = \sum_{k=1}^4 \frac{\partial N_k}{\partial \eta} y_k = -\frac{1}{4}(1-\xi) \cdot 0 - \frac{1}{4}(1+\xi) \cdot 0 + \frac{1}{4}(1+\xi) \cdot 2 + \frac{1}{4}(1-\xi) \cdot 1$$

$$\frac{\partial y}{\partial \eta} = \frac{1}{4}(3+\xi)$$

40

$$\det \mathbf{J} = \begin{pmatrix} \sum_{i=1}^4 \frac{\partial N_i}{\partial \xi} x_i \\ \sum_{i=1}^4 \frac{\partial N_i}{\partial \eta} y_i \end{pmatrix} - \begin{pmatrix} \sum_{i=1}^4 \frac{\partial N_i}{\partial \eta} x_i \\ \sum_{i=1}^4 \frac{\partial N_i}{\partial \xi} y_i \end{pmatrix}$$

$$\det \mathbf{J} = 1 \cdot \frac{1}{4}(3+\xi) - 0 \cdot \frac{1}{4}(1+\eta) = \frac{1}{4}(3+\xi)$$

$$\frac{\partial N_1}{\partial x} = \frac{1}{\det \mathbf{J}} \left( \sum_{k=1}^4 \frac{\partial N_k}{\partial \eta} y_k \right) \frac{\partial N_1}{\partial \xi} - \left( \sum_{k=1}^4 \frac{\partial N_k}{\partial \xi} y_k \right) \frac{\partial N_1}{\partial \eta}$$

$$= \frac{4}{3+\xi} \left( \frac{1}{4}(3+\xi) \cdot \left[-\frac{1}{4}(1-\eta)\right] - \frac{1}{4}(1+\eta) \cdot \left[-\frac{1}{4}(1-\xi)\right] \right) = \frac{1-\xi+\eta-\xi\eta}{4(3+\xi)} - \frac{(1-\eta)}{4}$$

$$= \frac{2\eta-\xi-1}{2(3+\xi)}$$

$$\frac{\partial N_1}{\partial y} = \frac{1}{\det \mathbf{J}} \left( \sum_{k=1}^4 \frac{\partial N_k}{\partial \xi} x_k \right) \frac{\partial N_1}{\partial \eta} - \left( \sum_{k=1}^4 \frac{\partial N_k}{\partial \eta} x_k \right) \frac{\partial N_1}{\partial \xi}$$

$$= \frac{4}{3+\xi} \left( 1 \cdot \left[-\frac{1}{4}(1-\xi)\right] - 0 \cdot \left[-\frac{1}{4}(1-\eta)\right] \right) = \frac{\xi-1}{3+\xi}$$

41

$$\int_{\epsilon} \frac{\partial N_1}{\partial x} \frac{\partial N_1}{\partial y} |\mathbf{J}| dx dy = \int_{-1}^1 \int_{-1}^1 \left[ \frac{2\eta-\xi-1}{2(3+\xi)} \cdot \frac{(\xi-1)}{3+\xi} \cdot \frac{3+\xi}{4} \right] d\xi d\eta$$

This is a RATIONAL function of the form

$$\int_{-1}^1 \int_{-1}^1 \frac{P(\xi, \eta)}{Q(\xi, \eta)} d\xi d\eta$$

And is integrated using a 2X2 Gauss Quadrature

$$\int_{-1}^1 \int_{-1}^1 \frac{P(\xi, \eta)}{Q(\xi, \eta)} d\xi d\eta = \int_{-1}^1 \int_{-1}^1 R(\xi, \eta) d\xi d\eta = \sum_{i=1}^2 \sum_{j=1}^2 w_i w_j R(\xi_i, \eta_j)$$

42

**2X2 Gauss points and weights**

$\xi_1 = -0.5773502692 d0$   
 $\xi_2 = 0.5773502692 d0$   
 $\eta_1 = -0.5773502692 d0$   
 $\eta_2 = 0.5773502692 d0$   
 $w_1 = 1.0 d0$   
 $w_2 = 1.0 d0$

**For the Bilinear element the 2X2 Gauss quadrature integrates the derivatives exactly. For general quadrilaterals the integrals are approximate.**

43

**In our example, integrating analytically:**

$$\int_{-1}^1 \int_{-1}^1 \left[ \frac{(2\eta - \xi - 1)(\xi - 1)}{8(3 + \xi)} \right] d\xi d\eta = \int_{-1}^1 \frac{1 - \xi^2}{4(3 + \xi)} d\xi = \frac{1}{4} \int_{-1}^1 \frac{-u^2 + 6u - 8}{u} du = 0.1129$$

**And integrating numerically:**

$$\int_{-1}^1 \int_{-1}^1 \left[ \frac{(2\eta - \xi - 1)(\xi - 1)}{8(3 + \xi)} \right] d\xi d\eta \cong \sum_{i=1}^2 \sum_{j=1}^2 w_i w_j R(\xi_i, \eta_j) = 0.11539$$

$R(\xi, \eta) = -\frac{(2\eta - \xi - 1)(\xi - 1)}{8(3 + \xi)}$

$R(\xi_1, \eta_1) = 0.128374$	$R(\xi_2, \eta_1) = 0.040348$
$R(\xi_1, \eta_2) = 0.006242$	$R(\xi_2, \eta_2) = -0.059578$

$\xi_1 = \eta_1 = -0.5773502692$   
 $\xi_2 = \eta_2 = 0.5773502692$   
 $w_1 = w_2 = 1.0 d0$

44