

El Bordo Siphon Junction Box Flow Numerical Simulation

Numerical Assumptions:

Flow rate $300 \text{ ft}^3/\text{s}$, inlet (8' RCP) velocity 6 ft/s with pipe flow (pressure flow with no open area), no backwater effect to the outlet (9' RCP) from downstream, total simulation time = 50 seconds

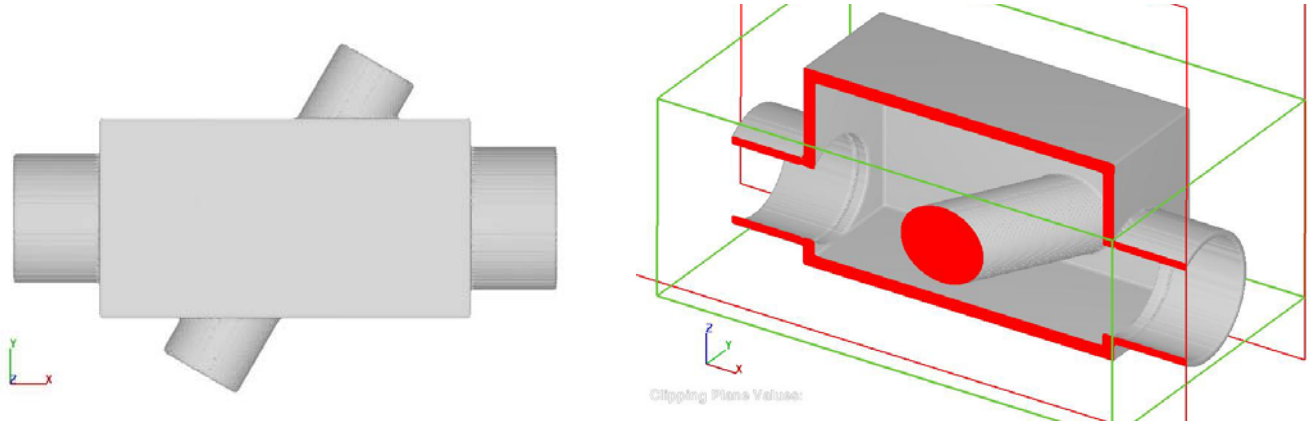

Junction Box Plan View and longitudinal section view – numerical model (see the construction plan sheet 7/8)

Results and Consideration:

With the current junction box design, flow will be delivered safely. After approximately 40 seconds, the box outlet flow rate (300 cfs) is getting stable (see the plot below). Very high velocity (12 ft/s) was simulated under the 5' DIP (red colored region in the figure below). See the time series simulation results (3-D view).

However, the inlet boundary condition (6 ft/s velocity with fully filled flow area) is an imaginary condition. Design flow rate and velocity are needed.

Flow retention due to the junction box is expected. To test backwater impact to upstream, the numerical model domain (8' RCP part) needs to extend.

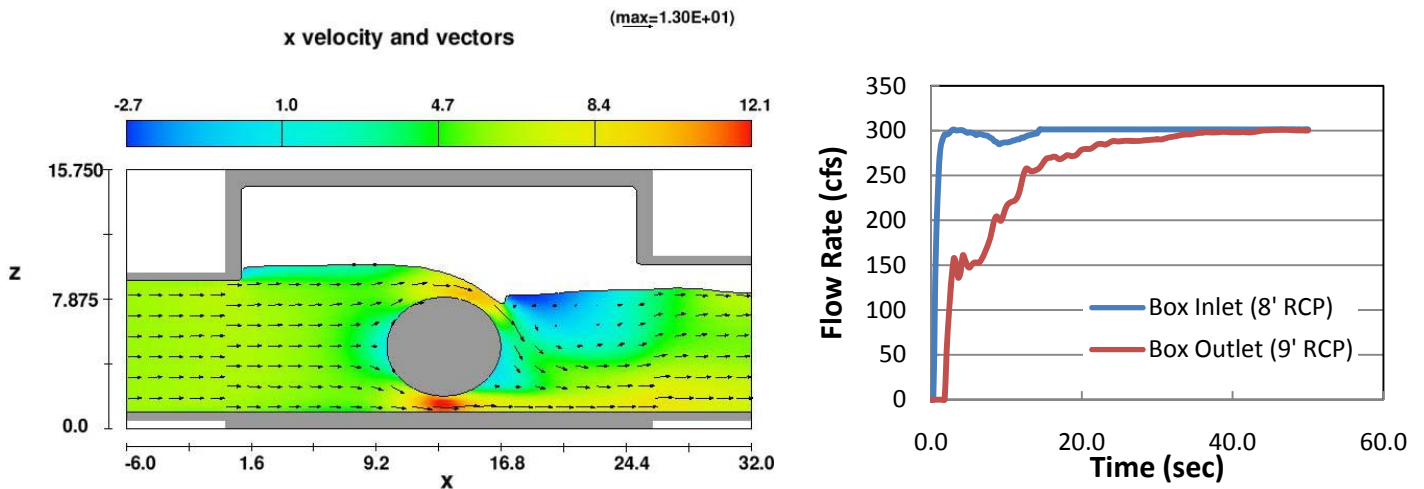

Velocity vectors and time series flow rate at the box inlet and outlet

