

ECE321 – Electronics I

Lecture 2: Basic Circuits with Diodes

Payman Zarkesh-Ha

Office: ECE Bldg. 230B

Office hours: Tuesday 2:00-3:00PM or by appointment

E-mail: pzarkesh.unm.edu

Review of Last Lecture

- Semiconductor technology trend and Moor's law**
- Benefits of transistor scaling:**
 - More functionality in the same foot print
 - Faster device
 - Devices with less switching energy
 - Less cost/function
- Challenges of transistor scaling:**
 - Device size reaching quantum level
 - Power dissipation and heat removal concerns
 - Interconnect worsen by scaling
 - Manufacturing yield issues
- Basic Logic Gates**
- DeMorgan's Law**
- Review of Basic Circuit Theory**
- Dynamic Power Analysis for Digital Circuits**

Today's Lecture

- Circuits with Nonlinear Devices (Diode)**
- Diode Basic Characteristics**
- Diode Approximations**
- Diode Application Circuits (Rectifiers)**

Vacuum Tubes: The First Nonlinear Element

Fleming Diode 1904

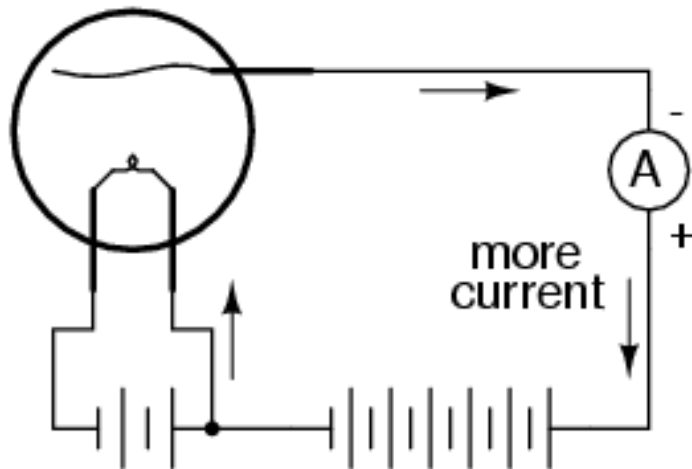

Courtesy of Prof. Ed. Graham

Evolution of Electronic Devices

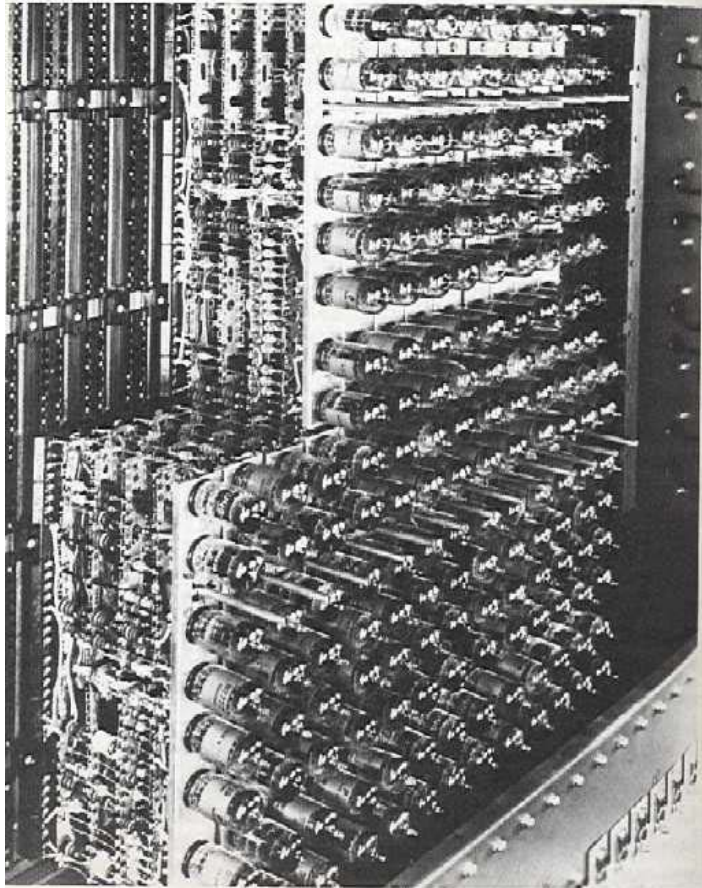

IBM Memory Bank – 1950's
(~1KB)

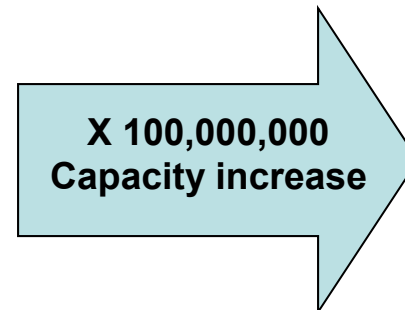

Today's SanDisk Memory Stick – 2014
(128GB)

Basic Diode I-V Characteristics

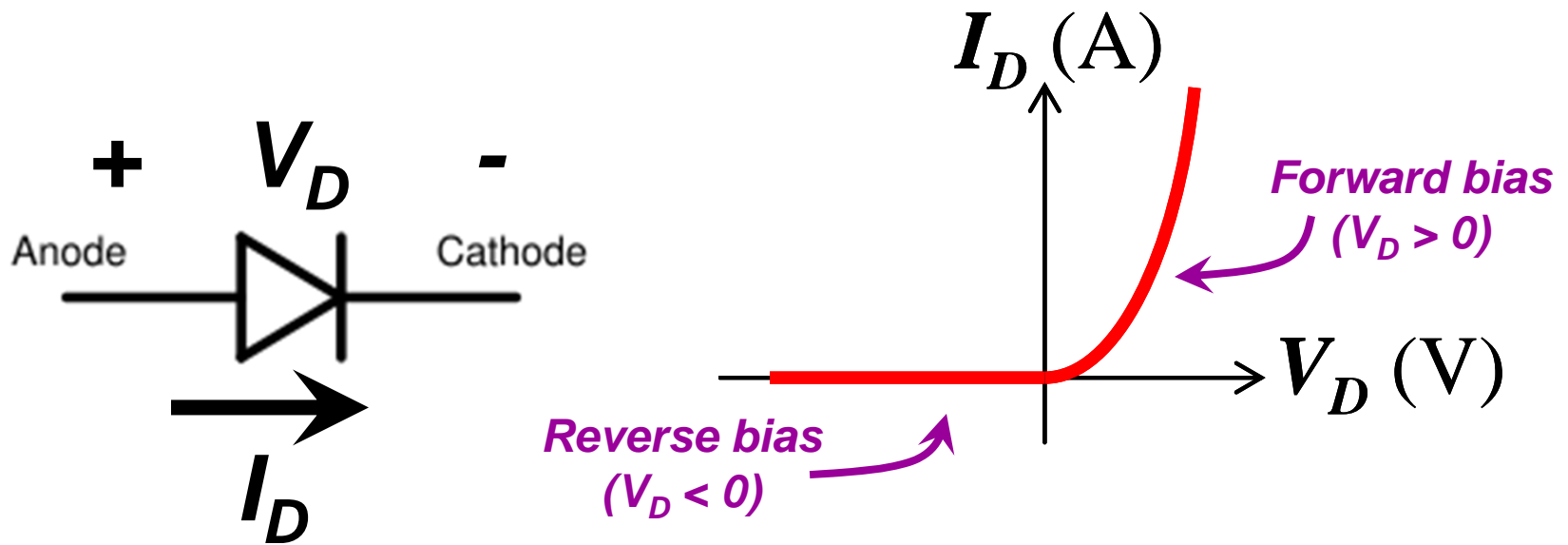

$$I_D = I_S \left(e^{V_D / V_{th}} - 1 \right)$$

Where I_s and V_{th} are constants (we will later show how to compute I_s and V_{th} based on device physics models)

Example: Basic Diode Characteristics

At room temperature (300K), V_{th} is about 26mV. Assume that I_s is 1pA and the diode current is 20mA.

- 1) What is the diode region of operation?
- 2) What is the diode voltage, V_D ?
- 3) If the diode current is 0A, what is the diode voltage?
- 4) If the diode voltage is -10V, what is the diode current?

Diode Zero, Reverse, and Forward Bias

- Reverse bias:

$$I_D = I_S \left[\exp\left(\frac{V_D}{V_T}\right) - 1 \right] \approx I_S [0 - 1] \approx -I_S$$

- Zero bias:

$$I_D = I_S \left[\exp\left(\frac{V_D}{V_T}\right) - 1 \right] \approx I_S [1 - 1] \approx 0$$

- Forward bias:

$$I_D = I_S \left[\exp\left(\frac{V_D}{V_T}\right) - 1 \right] \approx I_S \exp\left(\frac{V_D}{V_T}\right)$$

Some Diode Circuit Examples

Two circuits are shown with the diode anode connected to the positive terminal of a power supply ($I_s = 100 \text{ nA}$). What is V_o in both circuits?

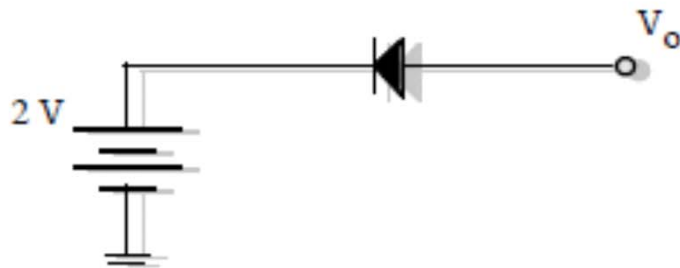

(a)



(b)

Diode in a Circuit: Exact Solution

Assume that V_{th} is about 26mV and I_s is 1pA. Find I_D and V_D (Q-point).

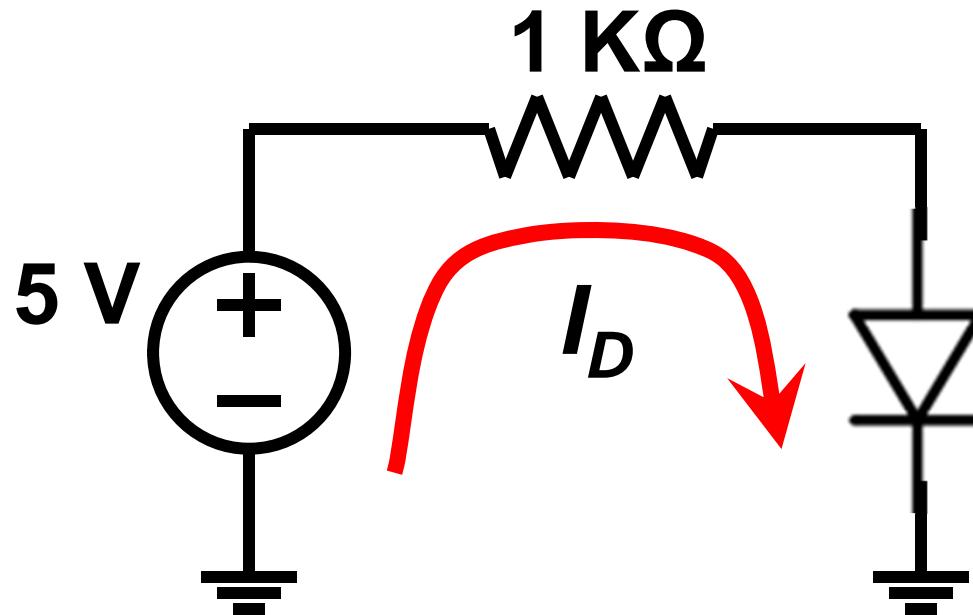

Answer: Q-point (4.42mA, 0.58V)

Load Line Analysis

- Graph the I-V relationships for the non-linear element (e.g. diode) and for the rest of the circuit (Thevenin Voltage and Resistor)
- The operating point of the circuit is found from the intersection of these two curves.

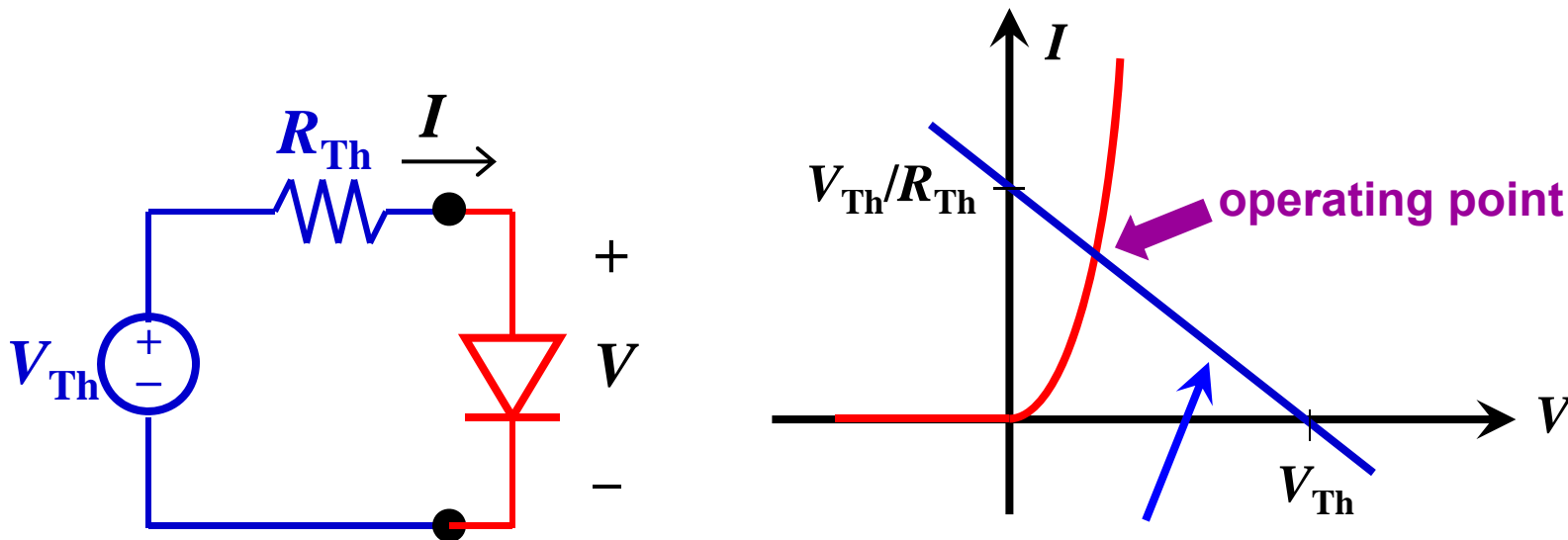

The I - V characteristic of all of the circuit except the non-linear element is called the load line

Ideal Diode Approximation

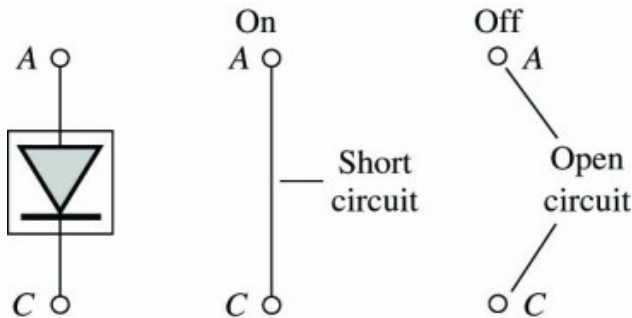
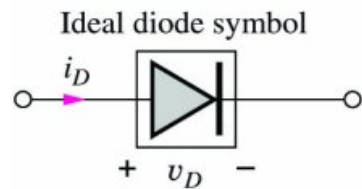
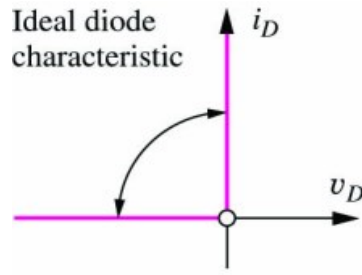

If diode is forward-biased, voltage across diode is zero. If diode is reverse-biased, current through diode is zero.

$$v_D = 0 \text{ for } i_D > 0 \text{ and } i_D = 0 \text{ for } v_D < 0$$

Thus diode is assumed to be either on or off.

Analysis is conducted in following steps:

- Guess diode's region of operation from circuit.
- Analyze circuit using diode model appropriate for assumed operation region.
- Check results to check consistency with assumptions.

Example: Ideal Diode Approximation

Find I_D and V_D (Q-point).

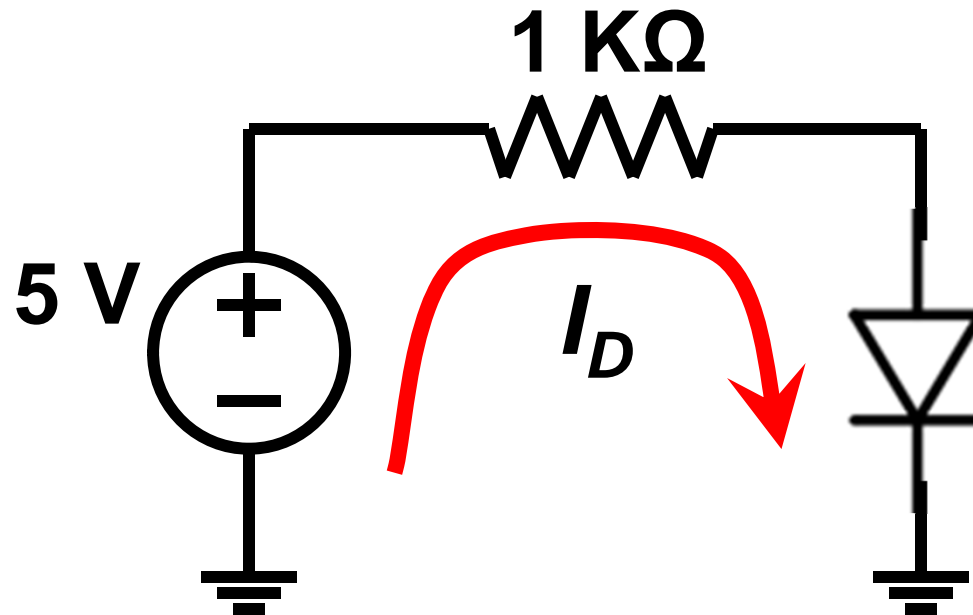

Ideal diode approximation: Q-point (5.00mA, 0.0 V)

Exact answer: Q-point (4.42mA, 0.58V)

Constant Voltage Diode Model

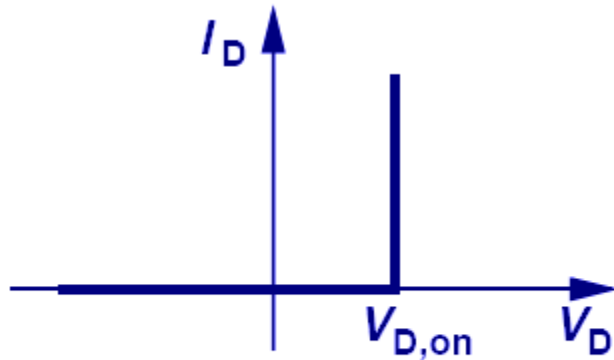

(a)

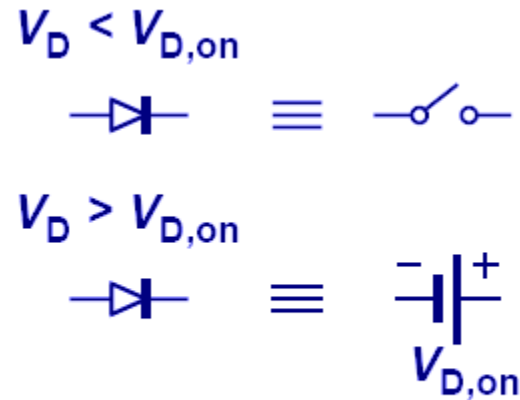

(b)

- If $V_D < V_{D,on}$: The diode operates as an open circuit.
- If $V_D \geq V_{D,on}$: The diode operates as a constant voltage source with value $V_{D,on}$.

Example: Constant Voltage Diode Model

Assume that $V_{D,on}=0.7V$. Find I_D and V_D (Q-point).

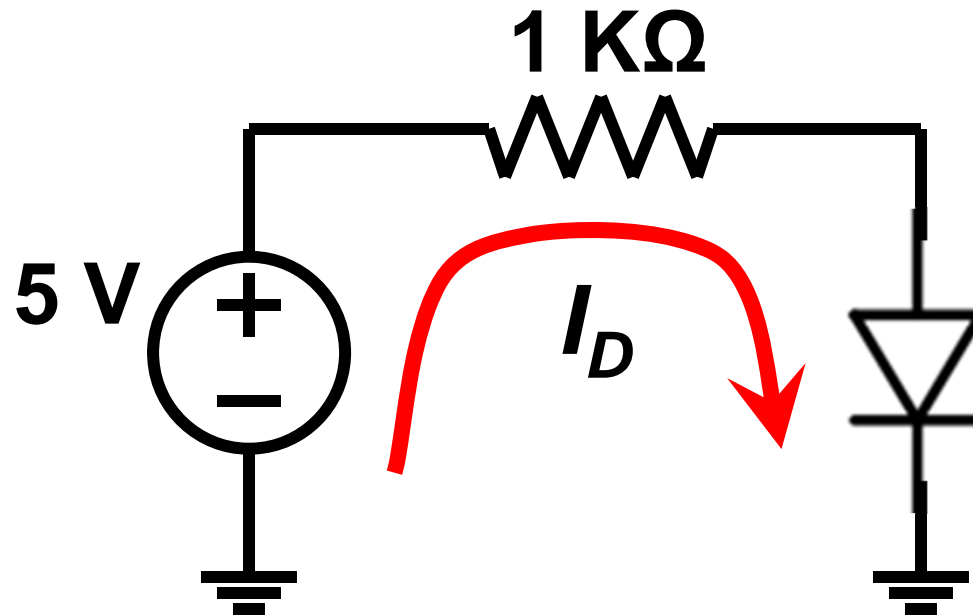

Constant voltage diode model: Q-point (4.30mA, 0.70 V)

Exact answer: Q-point (4.42mA, 0.58V)

How to Analyze Circuits with Diodes

A diode has only two states:

- **forward biased:** $I_D > 0$, $V_D = 0$ V (or 0.7 V)
- **reverse biased:** $I_D = 0$, $V_D < 0$ V (or 0.7 V)

Procedure:

1. Guess the state(s) of the diode(s)
2. Check to see if KCL and KVL are obeyed.
3. If KCL and KVL are not obeyed, refine your guess
4. Repeat steps 1-3 until KCL and KVL are obeyed.

Two Diode Circuit Analysis

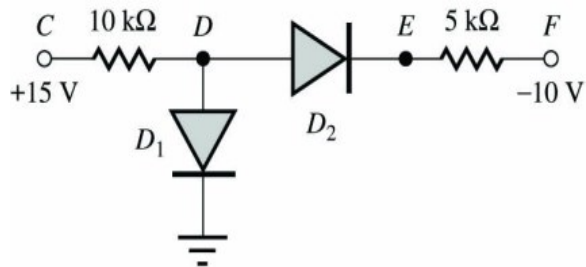

Analysis: Ideal diode model is chosen. Since 15V source is forcing positive current through D_1 and D_2 and -10V source is forcing positive current through D_2 , assume both diodes are on.

Since voltage at node D is zero due to short circuit of ideal diode D_1 ,

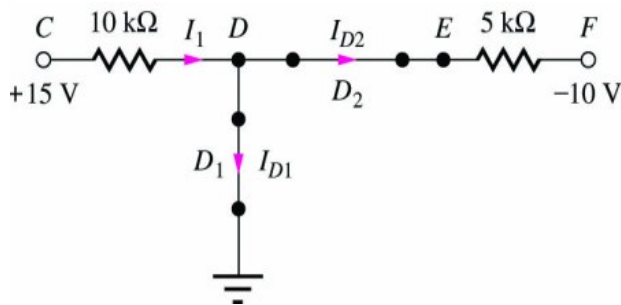

$$I_1 = \frac{(15 - 0)V}{10\text{k}\Omega} = 1.5 \text{ mA} \quad I_{D2} = \frac{0 - (-10)V}{5\text{k}\Omega} = 2 \text{ mA}$$

$$I_1 = I_{D1} + I_{D2} \quad I_{D1} = 1.5 - 2 = -0.5 \text{ mA}$$

Q-points are (-0.5 mA, 0 V) and (2.0 mA, 0 V)

But, $I_{D1} < 0$ is not allowed by diode, so try again.

Two Diode Circuit Analysis (Contd.)

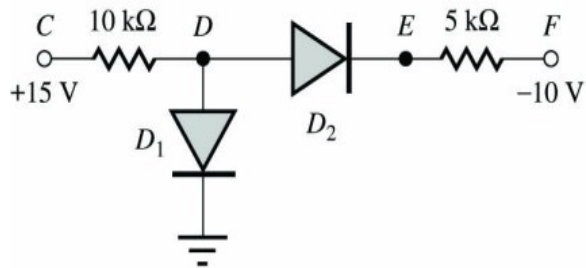

$$15 - 10kI_1 - 5kI_{D2} - (-10) = 0$$

$$I_1 = \frac{25V}{15k\Omega} = 1.67\text{mA}$$

$$V_{D1} = 15 - 10kI_1 = 15 - 16.7 = -1.67V$$

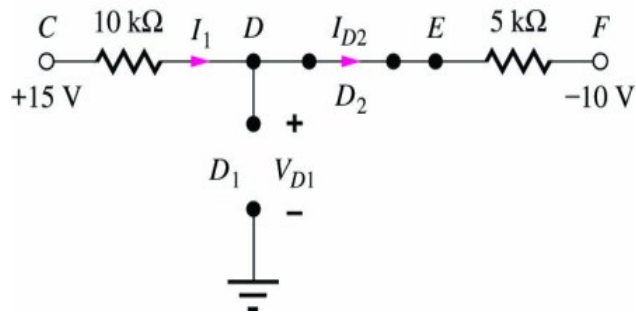

Analysis: Since current in D_2 but that in D_1 is invalid, the second guess is D_1 off and D_2 on.

Rectifier: Diode Practical Application

- Basic rectifiers convert an AC voltage to a pulsating DC voltage.
- A filter then eliminates pulsating components of the waveform to produce a nearly constant DC voltage output.
- Rectifier circuits are used in virtually all electronic devices to convert the 120V-60Hz AC power line source to the DC voltages required for operation of the electronic device.
- In rectifier circuits, the diode state changes with time and a given piecewise linear model is valid only for a certain time interval.

Half-Wave Rectifier with Resistive Load

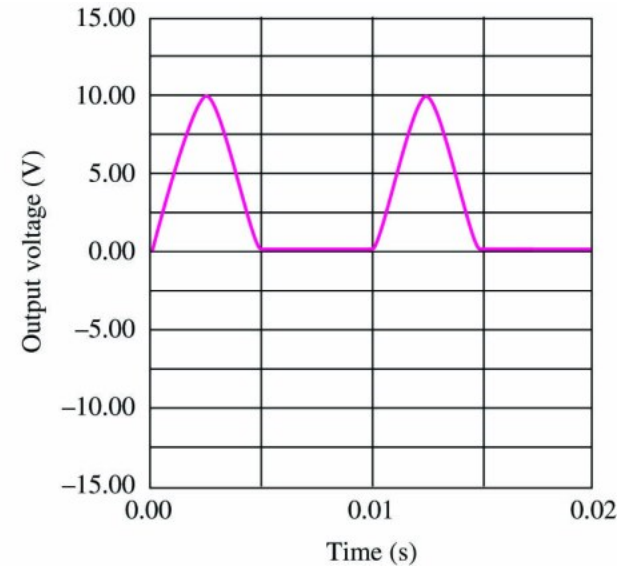
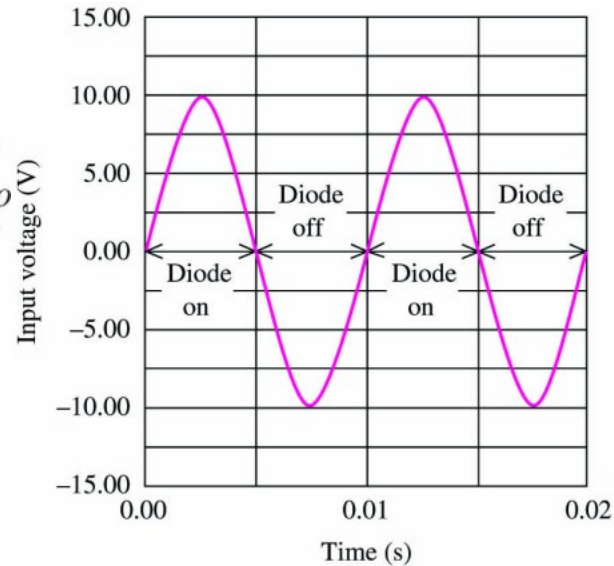
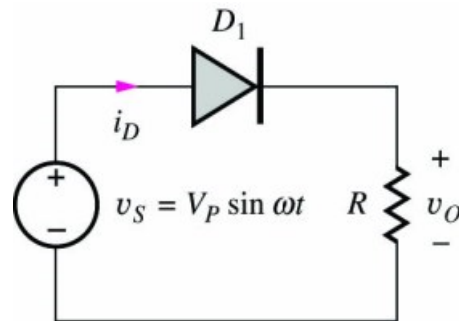

For positive half-cycle of input, source forces positive current through diode, diode is on, $v_o = v_s$.

During negative half cycle, negative current can't exist in diode, diode is off, current in resistor is zero and $v_o = 0$.

An ideal diode model is assumed here.

Half-Wave Rectifier Circuit (contd.)

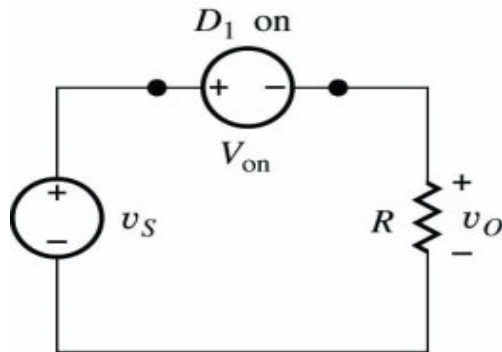

Using CVD model, during on state of diode $v_o = (V_p \sin \omega t) - V_{on}$. Output voltage is zero when diode is off.

Often a step-up or step-down transformer is used to convert 120 V-60 Hz voltage available from power line to desired ac voltage level as shown.

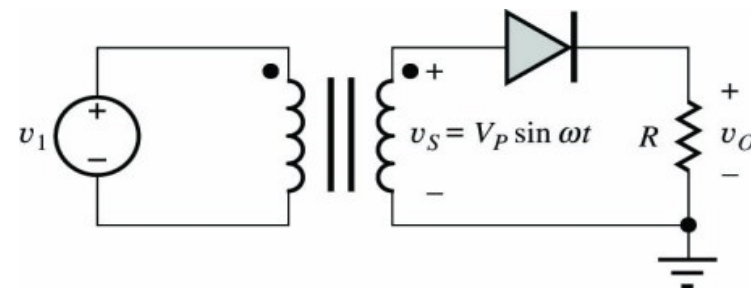
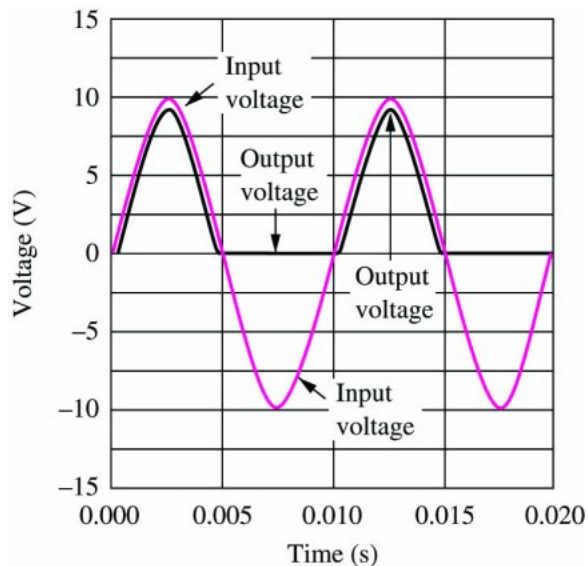

Time-varying components in circuit output will be removed using filter capacitor.

Half-Wave Rectifier with Capacitive Load

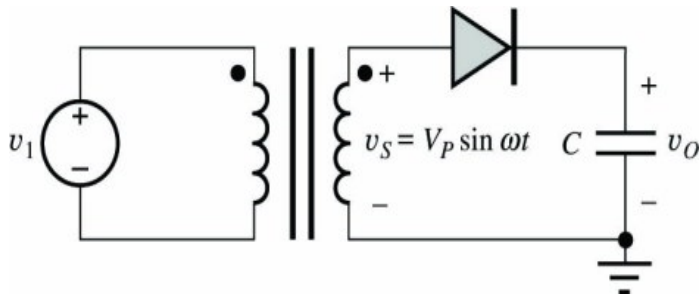

As input voltage rises, diode is on and capacitor (initially discharged) charges up to input voltage minus the diode voltage drop.

At peak of input, diode current tries to reverse, diode cuts off, capacitor has no discharge path and retains constant voltage providing constant output voltage

$$V_{dc} = V_P - V_{on}$$

With no load, filtering is easy.

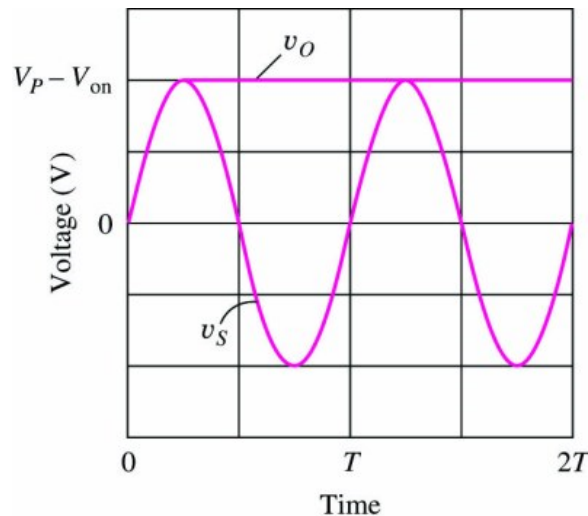

Half-Wave Rectifier with RC Load

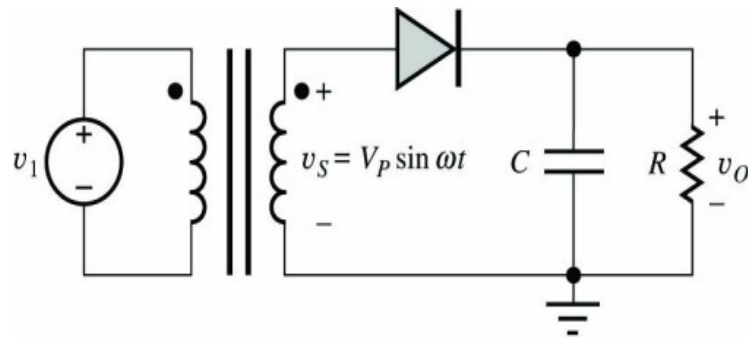

As input voltage rises during first quarter cycle, diode is on and capacitor (initially discharged) charges up to peak value of input voltage.

At peak of input, diode current tries to reverse, diode cuts off, capacitor discharges exponentially through R . Discharge continues till input voltage exceeds output voltage which occurs near peak of next cycle. Process then repeats once every cycle.

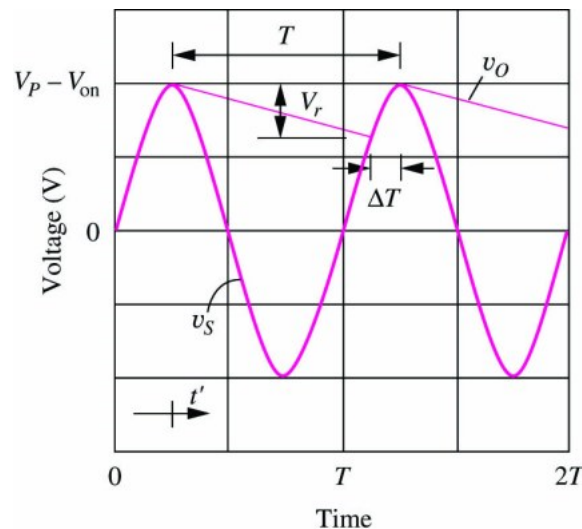

This circuit can be used to generate negative output voltage if the top plate of capacitor is grounded instead of bottom plate. In this case, $V_{dc} = -(V_P - V_{on})$

Half-Wave Rectifier with RC Load

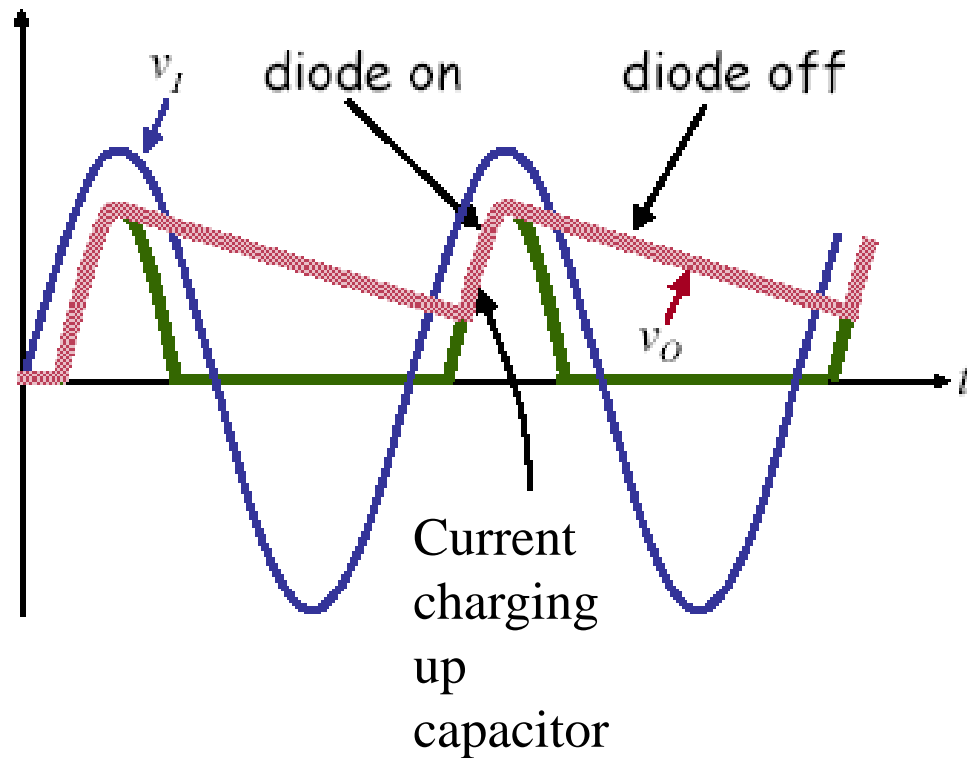
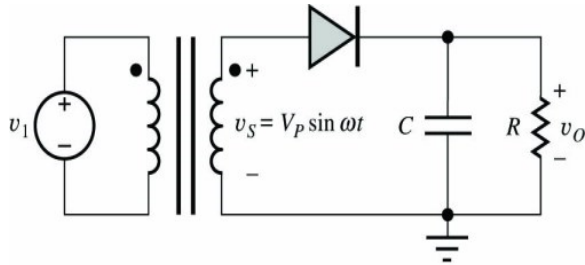

Full-Wave Rectifier with RC Load

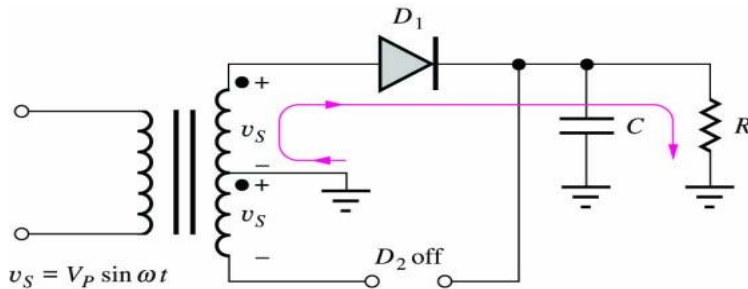
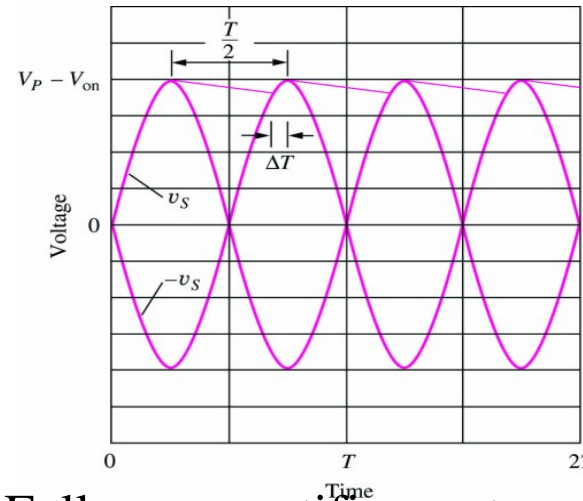
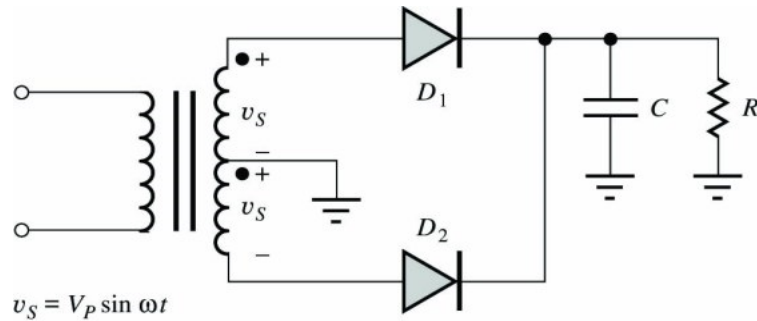

Full-wave rectifiers cut capacitor discharge time in half and require half the filter capacitance to achieve given ripple voltage. All other specifications are the same as for half-wave rectifiers.

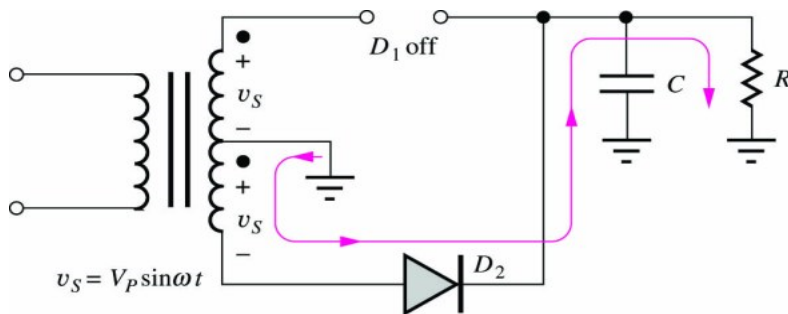

Reversing polarity of diodes gives a full-wave rectifier with negative output voltage.

Full-Wave Bridge Rectifier with RC Load

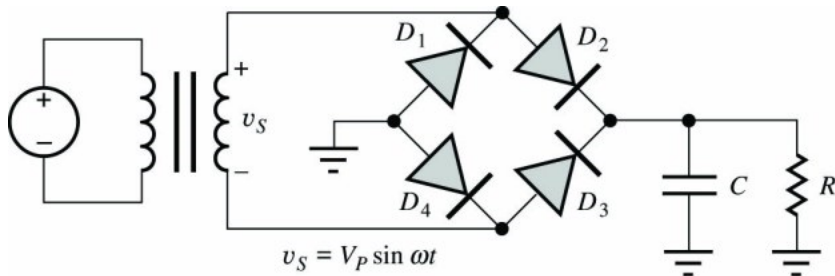

Requirement for a center-tapped transformer in the full-wave rectifier is eliminated through use of 2 extra diodes.

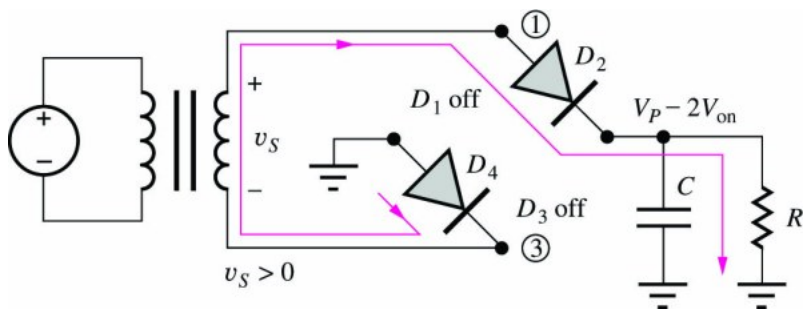

The four diodes in the bridge are available in a single 4-terminal package.

